

Arduino als Ersatzsteuerung

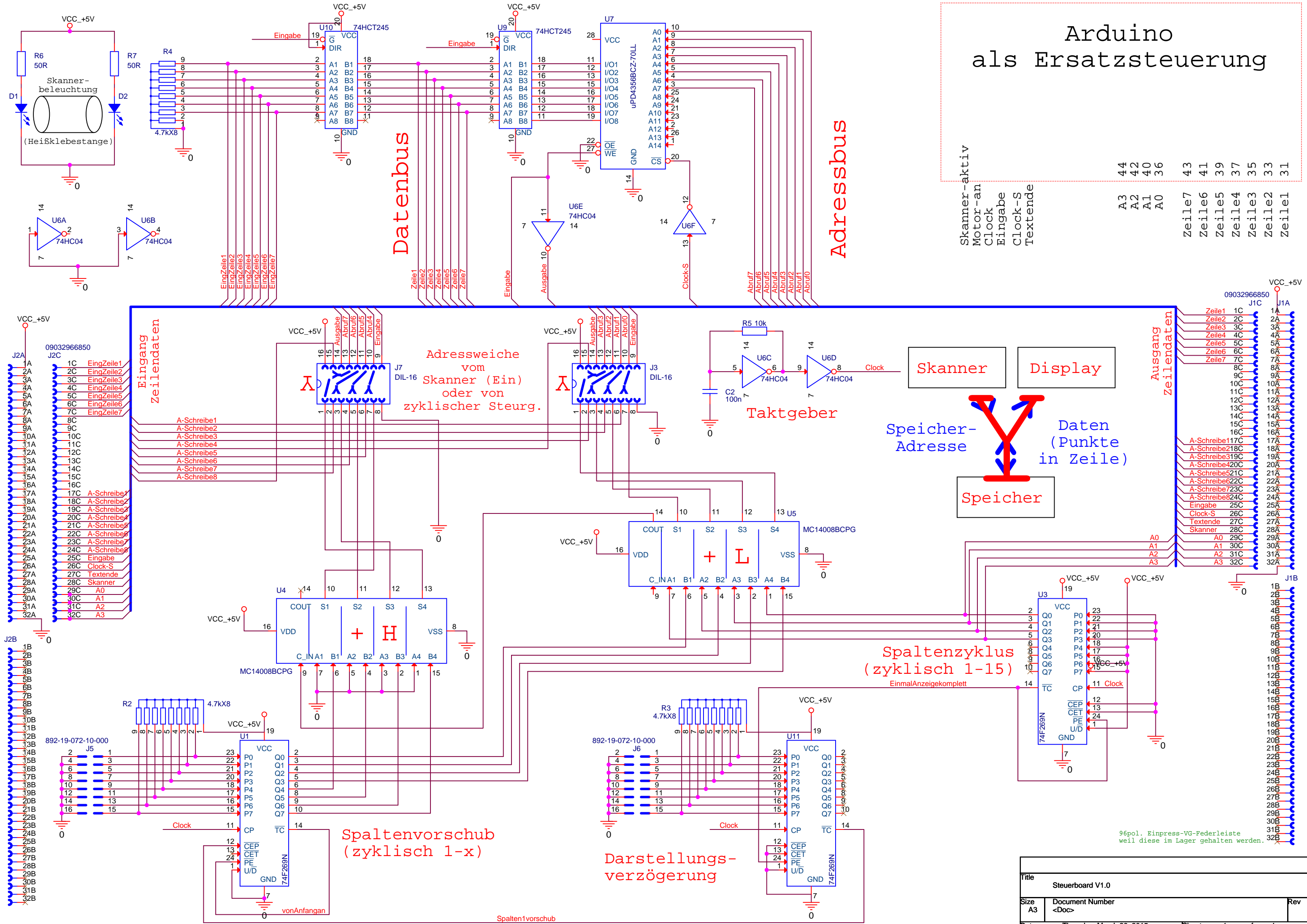

Skanner-aktiv	44	Zeile7	43
Motor-an	42	Zeile6	41
Clock	40	Zeile5	39
Eingabe	36	Zeile4	37
Clock-S		Zeile3	35
Textende		Zeile2	33
		Zeile1	31

