

**CRYOMECH**

**PT415**

**Helium Reliquefier**

**INSTALLATION, OPERATION and  
ROUTINE MAINTENANCE MANUAL**

The information contained in this document is believed to be accurate and reliable as of the time of its publication. However, Cryomech, Inc. cannot accept any responsibility (financial or otherwise) that may result from the use or misuse of the information contained in this document. Except as expressly contained in this document, there are no other warranties granted or extended by the manufacturer.

Cryomech, Inc. reserves the right to add, change, modify or delete any or all information contained herein without prior written notice. Revisions to this document may be issued at the time such changes and/or deletions occur.

Any duplication of this manual or any of its parts without expressed written permission from Cryomech, Inc. is expressly prohibited.

Correspondence concerning this document should be forwarded to:

Customer Service Department  
Cryomech, Inc.  
113 Falso Drive  
Syracuse, NY 13211 USA

Telephone (315) 455-2555  
FAX: (315) 455-2544

Email: [cryoservice@cryomech.com](mailto:cryoservice@cryomech.com)

Website: [www.cryomech.com](http://www.cryomech.com)

# Contents

Section 1  
Overview

Section 2  
Warranty

Section 3  
Safety

Section 4  
Inspection and Unpacking

Section 5  
Specifications

Section 6  
Installation

Section 7  
Operation

Section 8  
Routine Maintenance

Appendix A

Appendix B  
Spray Lubricant Instructions



## Section 1

# Overview

---

## Section 1: Overview

---

This section provides an overview discussion of Cryomech Helium Reliquefiers. It also provides an overview of this manual, including the organization, basic definitions of terms used and expansion of acronyms used in the manual.

### 1.1 Helium Reliquefier

#### 1.1.1 General description

The Cryomech Helium Re-liquefier is designed to recondense the boil off from liquid helium dewar/cryostats, and then return the Liquid Helium to the dewar/cryostat establishing a closed Helium loop. It can be installed into cryostats already full of liquid helium or be utilized to liquefy helium gas from gas cylinder to fill a dewar.

A 4 K pulse tube cryorefrigerator supplies the cryorefrigeration necessary to condense the helium inside the re-liquefier. The operation of a cryogenic refrigeration system is based on a closed-loop helium expansion cycle. A complete system consists of two major components: one is the compressor package, which compresses refrigerant and removes heat from the system; the other is the cold head, which takes the refrigerant through one or more additional expansion cycles to cool it down to cryogenic temperatures. The refrigerant gas used in the Cryomech cryogenic systems is 99.999% pure helium. Flexible stainless steel lines called helium flex lines carry compressed helium from the compressor package to the cold head and carry low-pressure helium back.

The compressor package works as follows. An oil-lubricated compressor compresses the pure low-pressure helium that is returned from the cold head. The heat of compression is removed via a heat exchanger, and the oil from the compression process is removed in a series of oil separators and filters. The compressed helium is then fed to the cold head via the high-pressure helium flex line.

In the cold head, adiabatic expansion of the helium and further heat removal allows cooling to cryogenic temperatures. The low-pressure helium then returns to the compressor package via the low-pressure helium flex line.

The Pulse Tube Cold Head is mounted in a vacuum insulated condensing chamber, referred to as the Re-liquefier Main Assembly. The room temperature helium gas/vapor returning from the cryostat dewar enters into the condensing chamber through the 1/4" O-ring fitting on the Re-liquefier Main Assembly. As the warm helium comes in contact with the Cold Head, its heat is absorbed into the heat exchangers on the Pulse Tube. This reduces its temperature, increasing its density, dropping it lower inside the condensing chamber; until it contacts the 4K condensing surface, where it condenses.

The Liquid helium is funneled into the Liquid helium Return Line which connects the bottom of the condensing chamber to the cryostat. **The return line is delicate and must be handled with care.**

Other components of the Helium Re-liquefier are a pressure controller, temperature monitor, electrical feedthrough, silicon diode, and heater assembly as well as a pressure relief valve and a vacuum port.

### **1.1.2 Features and benefits of the Cryomech Pulse Tube Cold Head**

The Cryomech Pulse Tube Cold Head has been carefully designed and manufactured to provide years of trouble free service.

#### **Primary features**

- Easy installation
- Cryomech Pulse Tube technology
- Fully automatic pressure controlled operation

#### **Primary benefits**

- Requires only electrical power and cooling water
- Very low vibration
- High reliability
- Long mean time between maintenance
- Reduced magnetic fluctuation from rare earth materials
- Lower costs of operation and maintenance

### **1.1.3 Features and benefits of the Cryomech Compressor**

#### **Primary features**

#### **Primary features**

The CPA2800 and CPA1000 Series Compressor Packages include Programmable Logic Controller (PLC) with the following features:

- Fault sensing
- Automatic error & data logging
- Remote operation
- Touch Screen interface
- Remote indication of faults
- Phase error sensing
- Serial & Ethernet communication

## **1.2 Cryomech Helium Reliquefier Manual**

This manual covers the complete Cryomech Helium Reliquefier. It is important that you review this manual carefully before beginning the installation process.

### **1.2.1 Organization of the manual**

The main body of the manual provides a detailed discussion of everything you will need in order to install and operate the Cryomech Cryorefrigerator and to perform routine maintenance. It is divided into 8 sections. Illustrations accompany the discussion as needed for clarification. Additional information will be in the appendix.

Numbered lists labeled with 1), 2), etc and lettered lists labeled with a., b., etc. are used for sequential actions that must be performed in the order listed. Lists for which order is not important are bulleted, using solid or hollow bullets.

The manual contains essential information for the safe and effective operation of your Cryomech Cryorefrigerator. Sections 2 and 3 clearly lay out all safety precautions you should take and also explain the ways in which you might inadvertently void your warranty by doing something that would damage the system.

Sections 4 through 8 provide complete step-by-step instructions on the handling of your Cryomech Cryorefrigerator, from inspection of the packing crate through routine maintenance. Each safety precaution is also shown in these sections in every place where observing the caution or warning is important.

- Section 1: Overview (including definitions and acronyms)
- Section 2: Warranty
- Section 3: Safety
- Section 4: Inspection and unpacking
- Section 5: Specifications
- Section 6: Installation
- Section 7: Operation
- Section 8: Routine maintenance
- Appendix: Additional information

## 1.3 Glossary

### 1.3.1 Definitions

The terms defined below are used with precision in the manual. For example, distinction is made between the (cryorefrigerator) system, the (compressor) package, and the (compressor) module.

The terms are in alphabetical order, and italicized terms within the definitions are terms that are also defined in this section.

#### Aeroquip® Couplings:

The term "Aeroquip® couplings" is used generically to describe the self-sealing fittings that connect components e.g. that connect *helium flex lines* to the *compressor package* and *helium flex lines* to the cold head.

#### Category II Installation:

Category II refers to the potential for transient over-voltage conditions in the mains power connection to the equipment. See IEC 664, Sub-clause 5.6 for further details.

#### Closed Loop System:

This refers to a cryogenic *system* that has no helium loss because the helium is cycled through a closed loop. The advantage of such a *system* is that there is no need to add helium.

#### Cold Head:

The cold head is an expansion device, which is capable of reaching *cryogenic temperatures*. In the AL or GB systems the cold head is a *Gifford-McMahon* style unit. In the PT series systems the cold head is a *Pulse Tube* style unit.

#### Cold Head Heat Exchanger:

The heat exchanger(s) on the *cold head* provide cooling at cryogenic temperatures by transferring heat to the helium within the system.

#### Cold Head Motor Cord

The cold head motor cord is pre-wired and fitted with electrical connectors on each end that attach to the *cold head* and *compressor package*. The cold head motor cord provides electrical power from the *compressor package* to the *cold head* motor.

#### Compressor Module:

Located inside the *compressor package*, the compressor module is an oil-lubricated commercial compressor that compresses low-pressure helium to the necessary high pressure.

#### Compressor Package:

The compressor package houses the *compressor module* and all other components that cool and purify helium and that provide system safety control. The compressor package compresses the low-pressure helium returning from the *cold head* and provides clean high-pressure helium to the *cold head*.

#### Cryogenic Temperatures:

Temperatures lower than 120K or -153°C.

#### Cryorefrigerator (Cryocooler):

A cryorefrigerator is a cryogenic refrigeration *system* based upon a closed loop helium expansion cycle. It consists of a *compressor package*, *helium flex lines* and a *cold head* (expansion device).

#### Gifford-McMahon (GM) Cryorefrigerator

A Gifford-McMahon cryorefrigerator is a *cryorefrigerator* in which the *cold head* expands the helium using a displacer or piston.

#### Helium Flex Lines:

The helium flex lines are corrugated stainless steel hoses that transport helium between the *compressor package* and the *cold head*.

#### Nitrogen Flexible Lines or Flex Lines:

Nitrogen flex lines are corrugated stainless steel hoses that carry nitrogen. These lines only apply to Liquid Nitrogen Plant models.

#### Pollution Degree 2:

Pollution degree 2 refers to the extent to which the local environmental conditions could affect the electrical safety of the system. See EN 61010 or UL 61010A for further details.

#### Pulse Tube Cryorefrigerator:

A pulse tube cryorefrigerator is a *cryorefrigerator* in which the *cold head* expands the helium using a pulse tube instead of a displacer or piston.



System:

The term "system" is used as a synonym for *cryorefrigerator*. It consists of a *compressor package*, *helium flex lines* and *cold head*.

### **1.3.2 Acronyms**

The following acronyms are used in the text and provided here for convenient lookup.

FPT Female Pipe Thread

GPM Gallons per Minute

LPM Liters per Minute

MPT Male Pipe Thread

OFHC Oxygen-Free High Conductivity (describes a form of Copper)

PSIG Pounds per Square Inch Gauge

## **1.4 Cryomech Contact Information**

Cryomech, Inc.  
113 Falso Drive  
Syracuse, NY 13211

Phone: +1 (315) 455-2555

Fax: +1 (315) 455-2544

Email: [support@cryomech.com](mailto:support@cryomech.com)

Website: [www.cryomech.com](http://www.cryomech.com)

## Section 2

# Warranty

## **Section 2: Warranty**

---

### **2.1 Statement of warranty**

Provided that the customer installs, operates and maintains this cryorefrigerator according to the specifications and procedures set forth in this manual, Cryomech, Inc. extends a warranty on all parts and workmanship for a period of three (3) years or 12,000 operating hours, whichever comes first. This warranty covers all non-user serviceable components of the compressor package, the cold head and the helium flex lines. The warranty does not cover user-serviceable parts (such as fuses).

If found to be defective and in accordance with the terms of the limited warranty, Cryomech will provide warranty replacement parts at no cost to the customer. Customers are responsible for all shipping and handling charges associated with warranty repair.

The Pulse Tube Cold Head is also warranted for the same three (3) years or period of 12,000 operating hours to deliver the specified temperatures and cooling capacities.

### **2.2 Conditions that can void the warranty**

- *Operation of the cryorefrigerator in any situation that does not meet the specifications in this section will void the warranty.* If you plan to operate the system outside any of the specified conditions, contact Cryomech. See Section 5.
- *Failure to follow these installation guidelines could result in voiding the warranty.* See Section 6.
- Because the tubes in the cold head must have very thin walls for cryogenic performance, extreme care must be taken when handling the cold head. Take special care to not dent or bend the tube assemblies. *The warranty will not cover dented or bent tubes.* See Section 6.
- *Operating the cold head in a magnetic field of greater than 500 gauss will void the warranty.* See Sections 6 and 7.
- Do not apply heat directly to the cold head (e.g. soldering anything to the cold head heat exchanger(s)). Doing so will damage the cold head and void the warranty. *The warranty will not cover heating of the cold head over 325K (125°F, 52°C).* See Section 6.
- In some applications, heavy components must be mounted to the cold surface. With the cold head oriented vertically, the maximum allowable load cannot exceed the value specified in Section 5. If your application requires a heavier load or an orientation other than vertical with a load, please contact Cryomech. An excessive load on the cold head can damage the tubes. *This type of damage is not covered under the warranty.* See Section 6.
- If the bolt pattern on the heat exchanger needs to be changed, you must consult Cryomech first to learn how to prevent damage to the cold head. *Holes drilled without prior approval from Cryomech will void the warranty.* See Section 6.
- Cooling water must meet the requirements in Section 5. *If water that does not meet the cooling water specifications in Section 5 is introduced into the system, even for cleaning purposes, it will void the warranty.* See Section 6.

- A voltage deviation of more than 10% above or below the voltage rating can cause compressor motor overheating and possible failure. *Indications of operation outside that voltage range will void the compressor warranty.* See Sections 6 and 7.
- Do not allow the flex lines to come into contact with corrosives or any type of commercial cleaning agent. *Helium leaks caused by exposure to corrosives or commercial cleaning agents will not be covered under warranty.* See Section 6.
- Do not bend the flex lines to less than 10 inch (25 cm) radius or permanent damage may occur. *This type of damage is not covered under the warranty.* See Section 6.
- The cold head contains no user-serviceable parts. *Attempting to disassemble the cold head will void the warranty.* Contact Cryomech if the cold head needs to be returned for servicing. See Section 8.
- When adding helium, the helium must be 99.999% pure. Contamination by other gases will result in the freezing of the contaminant gases in the cold head because their freezing temperature is much higher than that of helium. Contaminants in the helium charge will severely degrade the cold head's function and it will require factory servicing. *Contamination of the helium by other gases is a common cause of premature failure and, unless resulting from a system failure, is not covered by the warranty.* See Section 8.
- Never wet either part of the system. *Water getting into the system will void the warranty.* See Section 8.

## Section 3








# Safety

## Section 3: Safety

### 3.1 Safety and information symbols



#### 3.1.1 Equipment symbols



The safety and information symbol stickers placed on Cryomech Cryorefrigerators are defined below.

	Alternating current. The symbol signifies that alternating current is present.
	Internal ground. This symbol represents an internal protective grounding terminal. Such a terminal must be connected to earth ground prior to making any other connections to the equipment.
	Warning Icon. Refer to the documents that accompany the equipment.
	The CE label is placed on a product if the product has been tested for and meets the safety standards set by the European Community. CE stands for Conformité Européenne. All pressure equipment bearing the CE label has a maximum temperature of 94°C (200°F) and a maximum pressure 29barg (425psig).
	The TUV label is placed on a product if the product has been tested for and meets the safety standards set by the US and Canada. The cTUVus mark is officially recognized as an equivalent and direct replacement of the UL and CSA marks. Nation Recognized Testing Laboratories (NRTL) like TÜV Rheinland can test to the same standard and specifications as those defined by UL and CSA.
	Power switch. This symbol designates an in/out or push/push switch.
	Read the manual or handbook sign. When this symbol is found on a piece of equipment, the user should read the whole manual before starting installation or use. This symbol is found on the compressor package.

#### 3.1.2 Icons in the manual

Definitions of Warning and Caution and Information icons in the manual

	Warning Icon. A warning message is used when failure to observe instructions or precautions could result in injury or death to humans.
	Electrical Warning Icon. An electrical warning message is used when failure to observe instructions or precautions could result in electrical shock or burns to humans.

	Caution Icon. A caution message is used when failure to observe instructions or precautions could result in significant damage to equipment and/or facilities.
	Information Icon. The accompanying message contains information to aid the operator in obtaining the best performance from the equipment or other important information that does not involve danger to equipment or humans.

## 3.2 Warnings and cautions

Warnings and cautions for the Cryomech Cryorefrigerator system are listed here by subsystem. The same warnings and cautions appear in the appropriate places in the unpacking, installation, operation and routine maintenance sections of this document.

### 3.2.1 Section 5. Specifications

#### Section 5.2 Technical specifications



#### CAUTION

*Operation of the helium reliquefier in any situation that does not meet the specifications in this section will void the warranty. If you plan to operate the system outside any of the specified conditions, contact Cryomech.*

### 3.2.2 Section 6. Installation

#### Section 6.1 Reliquefier installation



#### CAUTION

*Operating the Reliquefier in a magnetic field of greater than 500 gauss will void the warranty.*



#### CAUTION

*The Liquid Helium Return Line extending out of the side of the Helium Re-liquefier Main Assembly is extremely delicate. **Please handle with care. Do not bend or adjust without contacting Cryomech.** The line is vacuum jacketed and constructed of very thin walled stainless steel tubing with very close tolerances.*

#### Section 6.2 Helium Reliquefier Installation into your Cryostat



#### NOTE

A liquid return line protector is attached to the Helium Re-liquefier assembly which is used for shipping, pre-installation, and storage purposes. It is wrapped in black and yellow caution tape for identification. Do not remove this until the Re-liquefier is ready to be lowered into the application. Do not is dispose of this part.

**Section 6.5 Compressor installation****CAUTION**

*Failure to follow these installation guidelines could result in voiding the warranty.*

**Section 6.5.1 Prepare the compressor package location****WARNING**

The compressor package must be positioned to provide easy access to the front-panel mounted circuit breaker.

**Section 6.5.2 Connect the water lines to the compressor****CAUTION**

Cooling water must meet the requirements in Section 5. *If water that does not meet the cooling water specifications in Section 5 is introduced into the system, even for cleaning purposes, it will void the warranty.*

**CAUTION**

Do not apply heat to the cooling water inlet and outlet connectors located on the front panel of the compressor.

**Section 6.5.3 Connect the compressor package to the main power****CAUTION**

A voltage deviation of more than 10% above or below the voltage rating can cause compressor motor overheating and possible failure. *Indications of operation outside that voltage range will void the compressor warranty.*

**WARNING**

Be sure to follow all local electrical codes and guidelines.

**WARNING**

One lead of the compressor package is grounded. Never bypass this ground or attach the compressor package to an ungrounded circuit. A dangerous electrical hazard will develop.



**Section 6.5.4 Connect the helium flex lines to the helium reliquefier assembly and the compressor package****CAUTION**

Follow the procedure carefully when connecting and disconnecting the helium flex lines. Failure to follow the procedure can cause accidental coupling disassembly, destruction of the sealing O-ring, and helium loss.

**CAUTION**

Do not allow the flex lines to come into contact with corrosives or any type of commercial cleaning agent. *Helium leaks caused by exposure to corrosives or commercial cleaning agents will not be covered under warranty.*

**CAUTION**

Do not bend the flex lines to less than 10 inch (25 cm) radius or permanent damage may occur. *This type of damage is not covered under the warranty.*

**WARNING**

Never remove the Aeroquip® couplings from the helium flex lines without first relieving the helium charge in the line to acceptable levels. The pressure in the hose can blow off the coupling with sufficient force to cause injury.

**3.2.3 Section 7. Operation****Section 7.1.1 Checks before operating****CAUTION**

A voltage deviation of more than 10% above or below the voltage rating can cause compressor motor overheating and possible failure. *Indications of voltage operation outside that range will void the compressor warranty.*

**CAUTION**

*Operating the helium reliquefier in a magnetic field of greater than 500 gauss will void the warranty.*

### 3.2.4 Section 8. Routine maintenance

#### Section 8.3 Cold head



#### **CAUTION**

The helium reliquefier contains no user-serviceable parts. *Attempting to disassemble the helium reliquefier will void the warranty.*

CONTACT CRYOMECH IF THE HELIUM RELIQUEFIER NEEDS TO BE RETURNED FOR SERVICING.

#### Section 8.4 Replace the adsorber



#### **CAUTION**

At no time should the Aeroquip® couplings be removed from the adsorber when replacing the adsorber. Replacement can be completed without relieving system pressure since the adsorber is equipped with Aeroquip® couplings for sealed removal.



#### **WARNING**

The input power must be disconnected from the helium compressor package before removing side panels.

#### Section 8.5 Vent excess helium



#### **CAUTION**

Venting more than 5 PSIG (.34 bar / 34 kilopascals) of helium per minute will lead to improper oil migration within the system. If this condition occurs, factory service will be required.

#### Section 8.6 Recharge helium



#### **CAUTION**

When adding helium, the helium must be 99.999% pure. Contamination by other gases will result in the freezing of the contaminant gases in the cold head because their freezing temperature is much higher than that of helium. Contaminants in the helium charge will severely degrade the cold head's function and it will require factory servicing.

*Contamination of the helium by other gases is a common cause of premature failure and, unless resulting from a system failure, is not covered by the warranty.*

**Section 8.7 Cleaning****CAUTION**

Never wet either part of the system. *Water getting into the system will void the warranty.*

**WARNING**

Never remove an Aeroquip® coupling from the helium flex lines, cold head or compressor without first relieving the helium charge. The pressure in any of the components can blow off the coupling with sufficient force to cause injury.

## Section 4

# Inspection and Unpacking

## **4 Section 4: Inspection and Unpacking**

---

### **4.1 Inspection of crate**



#### **IMPORTANT**

IF THERE IS ANY VISIBLE DAMAGE, DO NOT OPEN OR UNPACK THE PACKING CRATE BEFORE YOU CONTACT CRYOMECH.

Be sure to note on the shipping documents any visible damage to the crate, including tip indicators that have been activated.

### **4.2 Unpacking**

The system is packaged in a secure packing crate. The base of the packing crate is a pallet, to which the system is strapped. The walls of the crate are then placed around the system and attached to the pallet and each other with tension clips (Klimp® fasteners). After adding packing material as needed, the top is clipped onto the packing crate.

#### **4.2.1 Directions for unpacking:**

- 1) Remove the top of the packing crate by unfastening the Klimp® fasteners that fasten the top to the sides.
- 2) Check for tip indicators on the inside of the packing crate and notify Cryomech if interior tip indicators have been activated even though tip indicators on the outside were not.
- 3) Check for any visible signs of damage besides activated tip indicators.
- 4) Locate and remove the manual, and all other items that can easily be lifted out of the crate. The manual is packed in an envelope with the shipping documents.
- 5) Remove the sides of the packing crate by unfastening the Klimp® fasteners that fasten the sides to the pallet.
- 6) Remove packing material and any straps that anchor items to the pallet.
- 7) Remove the helium reliquefier box and set aside. See Section 4.3 for unpacking and inspection instructions.
- 8) Make sure that a place is prepared for the compressor package to sit (see directions in Section 6 for installation).
- 9) Retain the helium reliquefier box with all helium reliquefier packing materials and the packing crate to use in the future if you need to ship the equipment to Cryomech.

#### **4.2.2 Specific directions for moving when unpacking**

- 1) Move the helium reliquefier separately from the compressor. The helium reliquefier is much more fragile than the compressor and needs to be treated with care.
- 2) The compressor package needs to be lifted off the pallet base and onto the floor with a fork truck or a hoist. Some compressors are fitted with lifting eyebolts to aid in lifting

the compressor. See Section 5 for the weight of the compressor package. The compressor should not be tipped more than 5° at any time.

- 3) The compressor package is equipped with castors and can be rolled by hand after it is removed from the crate.

## **4.3 Inspection of equipment**

### **4.3.1 Packing list**

There is a packing list included with your system. The first step is to check that all parts listed on the packing list are included in the crate.

### **4.3.2 Compressor package**

Inspect the compressor package for any signs of damage such as dents, scratches or any signs of oil leaks.

There should be a tag on the front of the compressor package that states the pressure of each gauge and the ambient temperature at the time the pressure readings were taken. Check the pressure readings on both pressure gauges. If either gauge reads 5 PSIG (.34 bar / 34 kilopascals) lower than the recorded value, contact Cryomech.

### **4.3.3 Helium reliquefier**

- 1) Inspect the box that contains the helium reliquefier for any signs of physical damage.
- 2) Remove the screws holding the cover to the box and lift the cover.
- 3) Carefully remove packing material to expose the helium reliquefier. Retain the packing material for future use.
- 4) Carefully remove the helium reliquefier from the box and place on a clean, secure work surface.
- 5) Inspect the helium reliquefier for any damage, in particular, small dents on the tubes and any scratches, especially on the mounting surface of the base plate.
- 6) Retain the helium reliquefier box and packing material to use in the future if you need to store the helium reliquefier or ship it to Cryomech.

### **4.3.4 Helium flex lines**

Inspect the stainless steel helium flex lines for any signs of damage.

### **4.3.5 Cold head motor cord**

Inspect the cord for any signs of damage.

The cold head motor cord is completely pre-wired with connectors at each end that attach to the helium reliquefier and compressor.

### 4.3.6 Tool kit

Your Cryomech Cryorefrigerator system is shipped with a box of tools. The label on the box lists the contents included inside.

## 4.4 Returning a system to Cryomech

### Preparation of helium reliquefier, compressor, and helium flex lines

- 1) Contact Cryomech for an RMA number and for additional detailed instructions on how to properly return system components.
- 2) Repackage the system:



### **IMPORTANT**

Use the original helium reliquefier box to minimize the likelihood of damage during shipping.

- o Using the original packing material, rewrap the helium reliquefier and place in the original helium reliquefier box. The original helium reliquefier box and packing materials were designed to protect the helium reliquefier during return shipment.
  - o Place the compressor package on the pallet on top of sufficient vibration dampening material to prevent the wheels from touching the pallet.
  - o Strap the compressor package to the pallet, making certain that there is sufficient insulating material between the compressor and the straps so the straps will not scrape any paint off the compressor package.
  - o Using protective wrap, secure the original helium flex lines (included with compressor package) and place in container.
- 3) Be sure to include shipping labels on the box showing which side is up and making clear that the shipment is fragile.
  - 4) Cryomech highly recommends using “tip and tell” indicators. These indicators are helpful in determining whether your package was handled properly or not. Replace used “tip and tell” indicators with new ones (total of three).
  - 5) When the shipment is ready, please contact Cryomech for further instructions on shipping.

## Section 5

# Specifications



## Section 5: Specifications

### 5.1 Intended use of equipment

The Cryomech Helium Reliquefier is designed to recondense the boil off from liquid helium dewar/cryostats, and then return the Liquid Helium to the dewar/cryostat establishing a closed Helium loop. It can be installed into cryostats already full of liquid helium or be utilized to liquefy helium gas from gas cylinder to fill a dewar.

### 5.2 Technical specifications



#### **CAUTION**

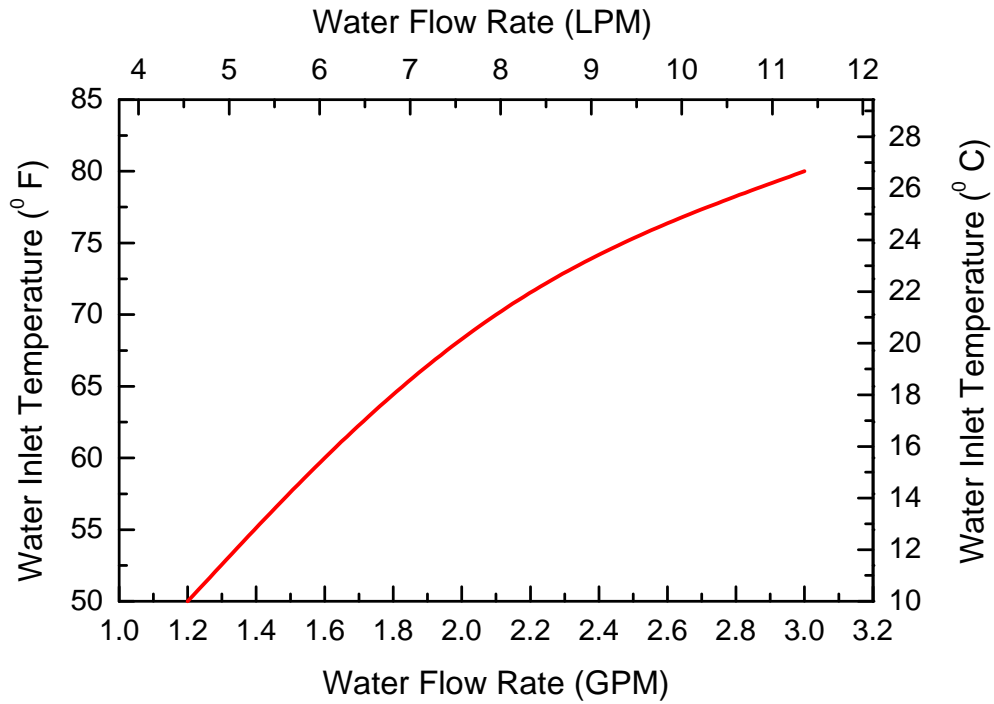
*Operation of the helium reliquefier in any situation that does not meet the specifications in this section will void the warranty. If you plan to operate the system outside any of the specified conditions, contact Cryomech.*

#### 5.2.1 Weights and dimensions

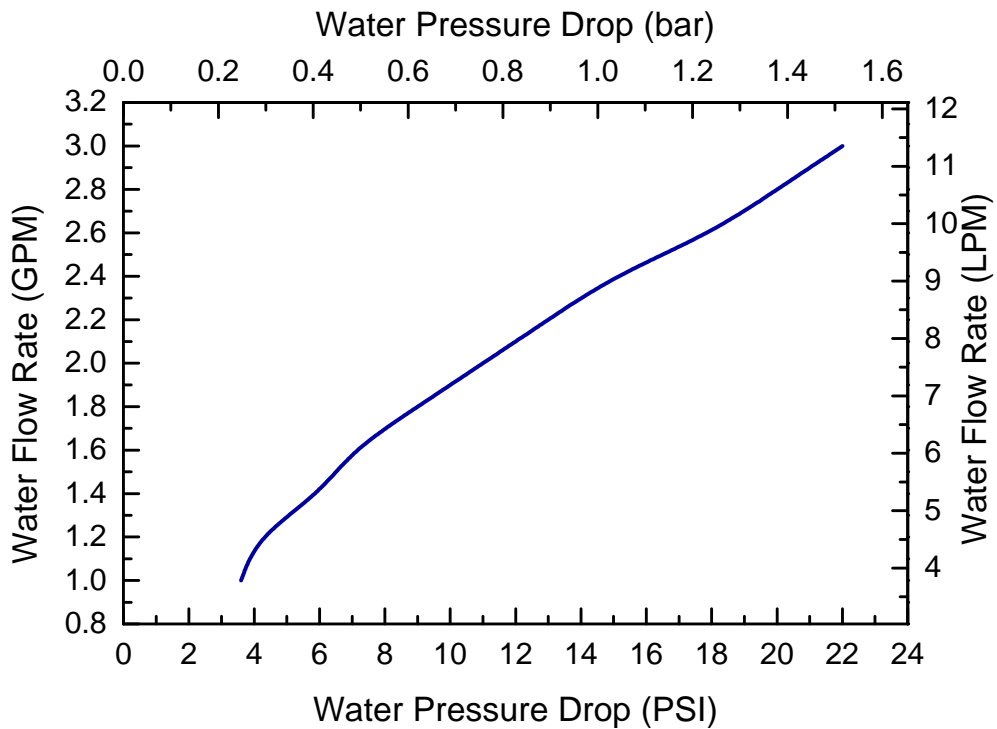
Parameter	Value	
Reliquefier Weight:	87 lbs.	39.4 kg.
Dimensions (L x W x H)	See Appendix A for outline drawing	
Helium Reliquefaction Capacity	≥15 L/day from room temperature gas ≥27 L/day from cryostat helium boil-off	

#### 5.2.2 Cooling water specifications

Parameter	Value
Cooling Water: minimum flow @ maximum temperature	<b>See Figure 5-1</b>
Maximum Inlet Pressure	110 PSIG / 7.6 bar
Alkalinity	5.8 < pH < 8.0
Calcium Carbonate	Concentration < 80 PPM



**Figure 5-1: Cooling water requirement\***



**Figure 5-2: Cooling water pressure drop\***

\* When using a 50-50% mixture of ethylene glycol and water, increase the flow rate 10%. Pressure drop values will increase 40%.

**5.2.3 Electrical specifications**

Parameter	200/230 Volt 60 Hz Model	440/480 Volt 60 Hz Model	200 Volt 50 Hz Model	380/415 Volt 50 Hz Model
Nominal voltage	200/230 VAC	440/480 VAC	200 VAC	380/415 VAC
Operating voltage range	180 - 253 VAC	396 - 528 VAC	180 - 220 VAC	342 - 456 VAC
Frequency	60 Hz	60 Hz	50 Hz	50 Hz
Phase	3	3	3	3
Mains supply voltage fluctuations	Up to ± 10% of the nominal voltage	Up to ± 10% of the nominal voltage	Up to ± 10% of the nominal voltage	Up to ± 10% of the nominal voltage
Input Power	See Appendix A			
Current				
Dedicated circuit breaker				

**5.2.4 Operating parameters**

Parameter	Value	
Ambient temperature range*	45 to 100°F	7 to 38°C
System helium pressure	230 ± 5 PSIG @ 60 Hz (15.86 ± .34 bar @ 60 Hz)	17.93 ± .34 bar @ 50 Hz (260 ± 5 PSIG @ 50 Hz)
Acceptable location	Indoors only	Indoors only
Maximum altitude for use	6560 ft	2000 m
Environment	Pollution Degree 2	Pollution Degree 2
Installation	Category II	Category II
Maximum relative humidity	80% for T < 88°F Decreasing linearly to 50% at 104°F.	80% for T < 31°C Decreasing linearly to 50% at 40°C.
Maximum sound level	70 dBA at 1 meter	70 dBA at 1 meter

\*The helium compressor package is designed to operate in an ambient temperature range from **45°F to 100°F (7 to 38°C)**. If the temperature is **below 45°F**, increased viscosity of the oil could prevent start-up and/or cause poor lubrication. Operation **above 100°F** will cause overheating and subsequent problems. If a unit must be subjected to either extreme, consult Cryomech, Inc.

**5.2.5 Safety devices**

A number of safety switches and valves are located inside the compressor package and on the cold head. They operate automatically, to protect the compressor package and cold head from developing extreme conditions that can cause damage. Most of them are totally transparent to the user and are monitored by the compressor control panel - see

**Section 7** for further detail. The safety devices listed below are not monitored by the compressor control panel.

#### **High-Pressure Relief Valve**

The compressor package high-pressure relief valve is set at **420 ± 5 PSIG (29 ± .34 bar)**. At pressures **above 420 PSIG (29 bar)**, the relief valve will open automatically and relieve pressure to the atmosphere.

#### **Internal Motor Overload Switch**

A motor overload switch, located inside the compressor module, protects the system by sensing excessive current draw and temperature. This switch automatically resets itself after the compressor module cools to an acceptable level.

#### **Cold Head High Pressure Relief Valve**

The cold head high-pressure relief valve is set at **425 ± 5 PSIG (29.3 ± .34 bar)**. At pressures **above 425 PSIG (29.3 bar)**, the valve will open automatically and relieve pressure to the atmosphere.

### **5.3 Description of the Helium Reliquefier**

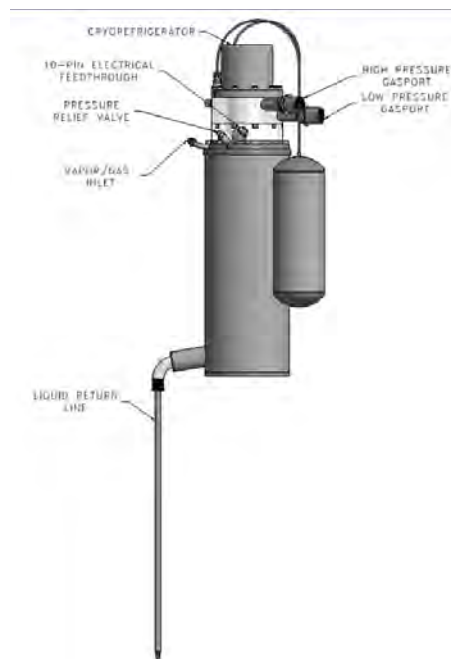
It has been standard practice in the design of liquid helium dewars/cryostats to use the liquid helium boil off to cool the cryostat neck, intermediate radiation shield, current leads, insert assembly, and other components of the cryostat that connect room temperature to the liquid helium. This practice is necessary to the overall efficiency of the cryostat. The Reliquefier condenses the helium boil off after it leaves the cryostat and then re-fills the cryostat through the existing fill port, turning the open cycle cryostat into a closed cycle system with no helium leaving the system.

The Pulse Tube Cryorefrigerator supplies the cooling to liquefy the helium. The complete cryorefrigerator consists of two major components: the Helium Compressor Package and the Pulse Tube Cold Head. The Helium Compressor Package supplies high and low pressure helium gas to the Pulse Tube Cold Head. The High Pressure helium is expanded inside the Cold Head to the low pressure, dropping in temperature to below 4K. The heat load can then be transferred into the Pulse Tubes 4K heat exchanger and returned to the Compressor Package, where it is removed into the cooling water. Two flexible stainless steel lines and a motor cord connect the Pulse Tube and the Compressor Package.

The Pulse Tube Cold Head is mounted into a vacuum insulated condensing chamber, referred to as the Reliquefier Main Assembly, as shown in Figure 5-3. The room temperature helium gas/vapor returning from the cryostat dewar enters into the condensing chamber through the KF16 flange on the Reliquefier Main Assembly. As the warm helium comes in contact with the Cold Head, its heat is absorbed into the heat exchangers on the Pulse Tube. This reduces its temperature, increasing its density, dropping it lower inside the condensing chamber; until it contacts the 4K condensing surface, where it condenses.

The Liquid helium is funneled into the Liquid helium Return Line which connects the bottom of the condensing chamber to the cryostat. **The return line is delicate and must be handled with care.**

Other components of the Helium Reliquefier are a temperature controller, electrical feedthrough, silicon diode, and heater assembly as well as a pressure relief valve and a vacuum port.



**Figure 5-3: Helium Reliquefier**

**A. Cryorefrigerator (Cold Head)**

The cold head is bolted to the top of the main assembly. An O-ring, located between the main assembly and the cold head, seals the helium gas inside the main assembly.

**B. 10-Pin Electrical Feedthrough**

The temperature diode receptacle is connected to a silicon diode and heater mounted to the cold head's helium condenser inside the main assembly. The diode cable connects this receptacle to the cold head temperature monitor and pressure controller.

**C. Vapor/Gas Inlet**

The boil-off helium from the dewar/cryostat enters the condensing chamber through the vapor/gas inlet.

**D. Pressure Relief Valve**

The pressure relief valve will begin to open when the pressure inside the dewar is approximately **5 PSIG**.

**E. Main Assembly**

Vacuum insulated condensing chamber that houses that cryorefrigerator.

**F. Liquid Return Line**

The recondensed helium is returned to the dewar via liquid return line which connects the condensing chamber to the dewar/cryostat forming a closed cycle.

**G. High Pressure Gasport**

The high-pressure gasport fastens to the high-pressure helium flex line that supplies compressed helium gas from the compressor package to the cold head.

**H. Low Pressure Gasport**

The low-pressure gasport fastens to the low-pressure helium flex line that returns helium gas from the cold head to the compressor package.

**I. Pressure Relief Valve**

The pressure relief valve will begin to open when the pressure inside the dewar is approximately **5 PSIG**.

## **5.4 Operation of the Helium Reliquefier**

The Helium Reliquefier and your cryostat must first be connected as shown in Figure 5-4. The liquid return line is inserted into the fill port of your cryostat. The vapor line connects the vent of helium vapor to the gas inlet of the reliquefier.

Please note that your open dewar/cryostat is now a component of a larger closed system. The term "closed" means that no air should enter the system and no helium should leave it. The helium that boils off and cools the components of the cryostat exits the cryostat through the neck, carrying the heat from the cryostat to the reliquefier, where the heat is removed from the system. When the heat is removed from the helium it re-condenses in the Reliquefier Main Assembly. The natural convection establishes a flow inside the system. This circulation loop, also called a thermo-siphon, forces the gas cooling and condensing in the main assembly in one direction.

The liquid helium flows down the liquid return line into the cryostat. For maximum performance, it is important that the liquid helium leaves the liquid return line inside your cryostat at a level which is in the gaseous helium and < 8K. To install the Helium Reliquefier, Cryomech recommends that you plan that the bottom end of the return line is near the "full" liquid level in your cryostat. Please be sure the liquid return line is matched with the fill port of your cryostat.

For optimum performance the helium vapor line should connect to the cryostat instrumentation port so the helium vapor can be used to cool the leads and the shield according to the dewars original design. There is a needle valve on the helium vapor line to control the flow of the thermo-siphon loop. The thermo-siphon flow in some cryostats could be very strong and decrease the liquefaction for your application. We recommend that the needle valve is open to between 33-50%; and is set this way by Cryomech. Minor adjustments might increase the liquefaction rate for some installations. If ice forms on your vapor return line contact Cryomech for directions.

It is necessary to balance the rate of boil off of your cryostat with the condensing rate of the Pulse Tube Cryocooler. Therefore, Cryomech, Inc. has included a pressure controller to the system. There is a temperature sensor/monitor and heater assembly attached to the 4K condensing surface of the Cold Head. Heat will be added to the 4K condensing surface to ensure that the cryostat pressure does not go below 3 psig, the desired vapor pressure/liquid temperature of the cryostat. Without the heating, the Pulse Tube Cryocooler could cool to a temperature below the design temperature of the cryostat and generate a vacuum in the cryostat.

For example: If your cryostat has a boil off rate of 9 liters/day and the PT410 Cold Head is capable of recondensing 11 liter/day in “your installation,” heat must be added by the pressure controller to reduce the effective recondensing rate of the PT410 Cold Head. If this does not happen effectively, the pressure inside the cryostat will drop below 1<sup>+</sup> Atmosphere, which Cryomech does not recommend.

If the pressure inside the system drops to below 1 Atm., air might enter the system and solidify on the Cold Head heat exchangers. This will reduce the efficiency of the Helium Reliquefier and possibly block the flow of liquid helium through the return line.

The Helium Reliquefier has been designed to operate with cryostats that have already been filled with liquid helium. But for small cryostats, the Helium Reliquefier can cool down the cryostat from room temperature and fill it with liquid helium. For this application, a helium gas supply from a gas cylinder and a pressure regulator will be required.

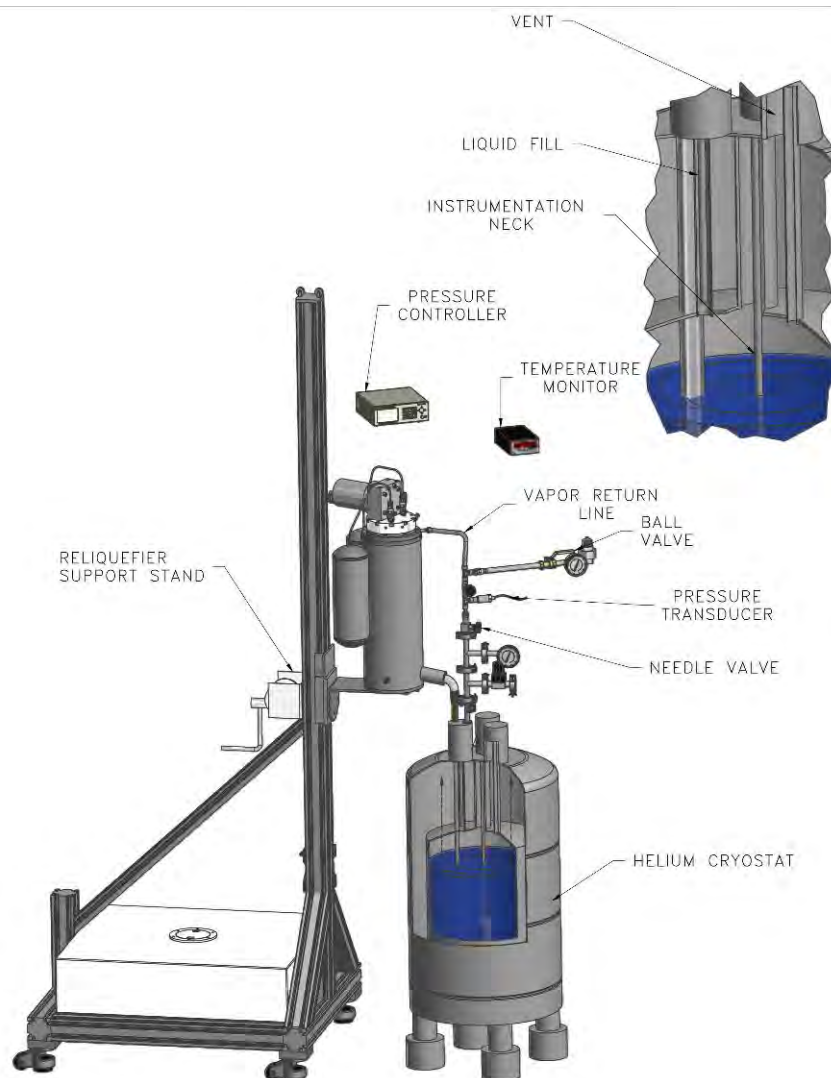
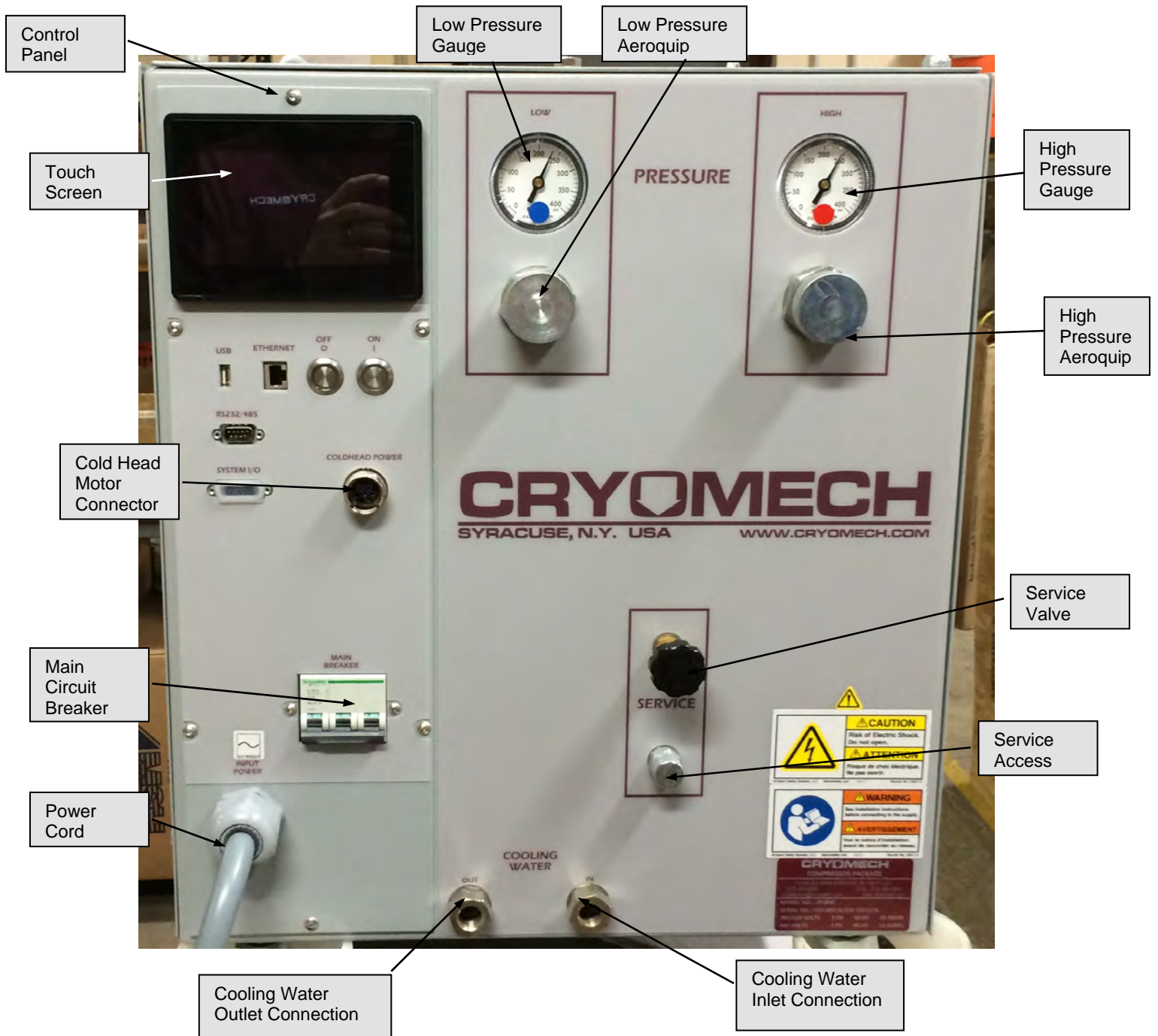


Figure 5-4: Helium Reliquefier to cryostat installation

## 5.5 Description of compressor



**Figure 5-5: Front panel of the compressor package**

### 5.5.1 Front panel interfaces

This section describes the function of all operator interfaces on the front panel of the CPA1000 Series Compressor Package, including switches and valves. It also describes the functions of all connectors, electrical cords and gauges on the front panel.



**Low-Pressure Aeroquip®**

The low-pressure helium flex line (not shown) fastens to the low-pressure Aeroquip® that returns helium gas from the cold head to the compressor package.

**Low-Pressure Gauge**

The low pressure gauge displays the pressure of the helium gas that is being returned to the compressor package. When the compressor package is off and the *complete system is at room temperature*, the gauge should read the pressure specified in Appendix A.

**High-Pressure Aeroquip®**

The high-pressure helium flex line (not shown) attaches to the high-pressure Aeroquip® that supplies compressed helium gas from the compressor package to the cold head.

**High-Pressure Gauge**

The high-pressure gauge displays the pressure of the compressed helium gas that is transported from the compressor package. When the compressor package is off and the *complete system is at room temperature*, the gauge should read the pressure specified in Appendix A.

**Control Panel**

The control panel houses the compressor controls and system display.

**Cold Head Motor Connector**

The cold head motor cord attaches to the cold head motor connector to provide power from the compressor package to the cold head motor or remote motor assembly.

**Main Circuit Breaker**

The main circuit breaker provides over-current protection for the cryorefrigerator and also functions as a main power disconnect.

**Service Valve**

The service valve is the valve used to regulate the amount of helium being added to or released from the system.

**Service Access**

The service access is used in conjunction with the service valve for adding helium to or releasing helium from the system.

**Cooling Water Inlet Connection**

The cooling water inlet connection provides water to the compressor package from your facility to cool the compressor package during operation. The connector thread size is a 3/8 FPT (3/8" Female National Pipe Thread).

The water must meet the specifications provided in the Cooling Water Specifications table in Section 5.

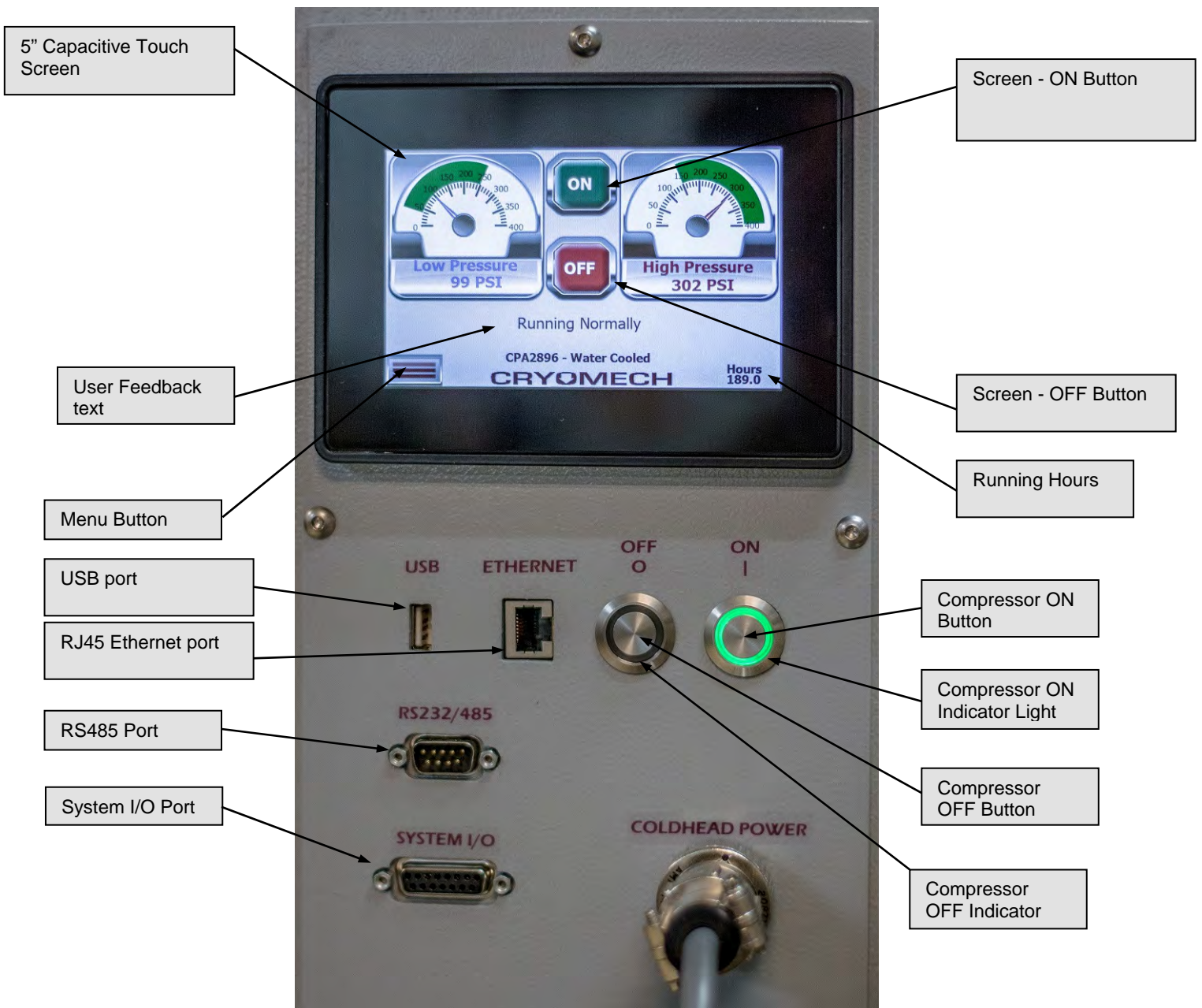
**Cooling Water Outlet Connection**

The cooling water outlet connection carries heated water away from the compressor package after the water has been heated by cooling the compressor package during operation. The connector thread size is 3/8 FPT (3/8" Female National Pipe Thread).

**Power Cord**

The power cord supplies power from the wall to the entire system.

**5.5.2 Control panel description**



**Figure 5-6: Control panel of the compressor package**

**Compressor ON Button**

The compressor ON button is a mechanical button used to start the compressor system.

**Screen - ON Button**

The screen ON button is a digital button used to start the compressor system. Its function is the same as the compressor ON button. The button is only available on the main screen.

**Compressor ON Indicator Light**

The Compressor ON indicator light is illuminated when the compressor is operating.

**Compressor OFF Button**

The compressor OFF button is a mechanical switch used to stop the compressor system.

**Screen OFF Button**

The screen OFF button is a digital button used to stop the compressor system. Its function is the same as the compressor OFF button. The button is only available on the main screen.

**Compressor OFF Indicator Light**

The Compressor OFF indicator light is illuminated when the compressor is switched off with the Compressor Off button or when one of the compressor's internal safety switches has tripped.

**5" capacitive touch screen**

The touch screen displays system status, warnings, error messages, and the various other operation data. It is also used to navigate through the various menus and sub screens allowing the user to access data about the compressor system.

**User Feedback text**

The user feedback text tells the operator the status of the compressor including any errors or warning which may occur.

**Running hours**

The running hours displays the current running (operating) hours of the compressor. (This does not include any idle or off time.)

**Menu Button**

The menu button is used to navigate the system providing additional control and monitoring.

**USB Port**

The USB Port can be used to download recorded data from the system.

**RJ45 Ethernet Port**

The RJ45 port can be used to remotely monitor and control the compressor system. Refer to the compressor's user guide or contact Cryomech for more information

**RS485 Port**

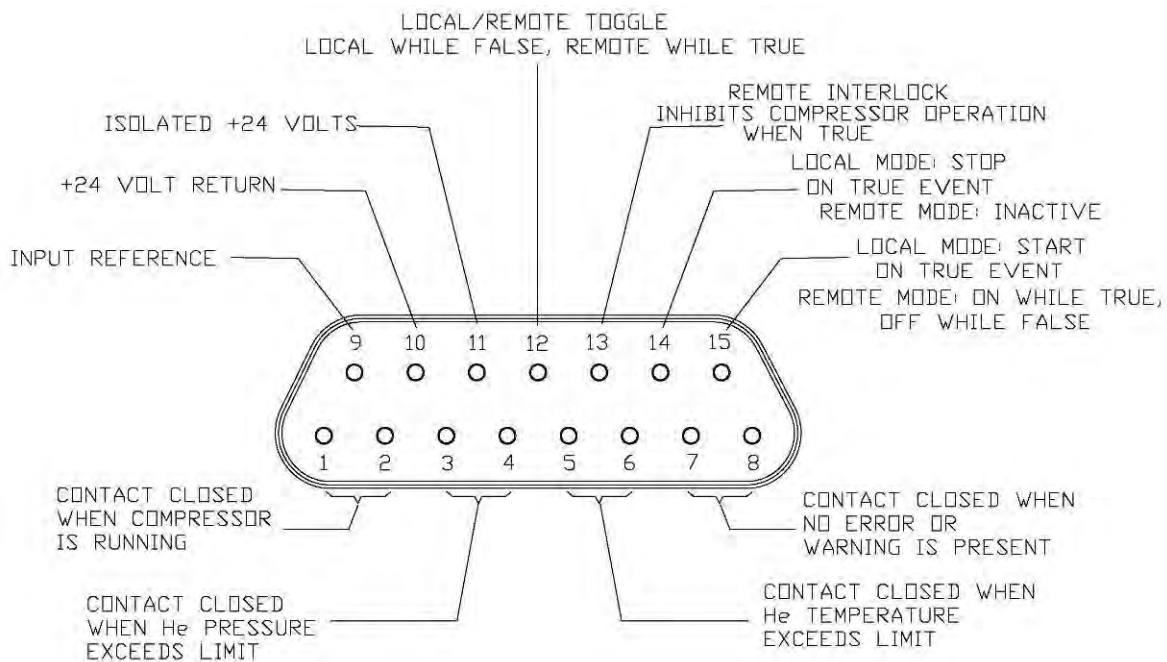
The RS485 port can be used to remotely monitor and control the compressor system. Refer to the compressor’s user guide or contact Cryomech for more information

**System I/O Port**

The System I/O port is a DB15 female socket that can be used to remotely control the compressor package and monitor a limited number of its parameters. A detailed description follows.

**System I/O**

A 15 pin digital I/O connector with selected input controls and relay outputs is provided for limited monitoring and control. The digital I/O and its associated DB15 female (socket) connector are described in this section.



**Figure 5-7: 15 Pin connector diagram**

**Inputs**

Three remote inputs are provided to start, stop and inhibit operation of the compressor.

For INPUTS, a low or false is a voltage differential of less than 6VDC (Max1mA) between the input pin and IN\_REF (pin 9). The input pin being – (neg) and the IN\_RET pin being + (pos).

An open circuit (no connection to the input pin) is also low (false).

High or true is a voltage differential between the input pin and IN\_RET that exceeds 12VDC. The input pin being – (neg) and the IN\_RET pin being + (pos).

Rising edge is a change in the pin state from false to true.

Falling edge is a change in pin state from true to false.

Again, all inputs reference to pin 9. For example, to generate a true condition on an input connect the input reference IN\_REF to a positive DC voltage (greater than 12 volts and

less than 30 volts(Min3mA) and close the selected input pin to the return of that supply. (An isolated 24 volt supply and return is provided on pins 11 and 10 of this connector respectively.)

The minimum pulse width (high or low) for an input signal to be recognized is 200ms. It is possible for a signal to be recognized sooner, but due to the asynchronous nature of the design, a 200ms pulse width is necessary to guarantee the signal is recognized.

Maximum input voltage without damage to the hardware is  $\pm 30V$ , indefinite time.

Minimum guaranteed "TRUE" voltage is +12VDC.

Negative voltages are considered FALSE.

Input "impedance" is about 3.3K Ohm.

Inputs are ESD protected.

### **Outputs**

Four standard outputs are provided. They are relay closures which indicate that the compressor motor is running, the helium temperature or pressure has exceeded set limits or that no errors or warnings have been detected.

All outputs are contact closures (rated at 2amps 24 VDC).

### **Isolated voltage supply**

Pin 11 is an isolated (1000VDC) +24VDC source referenced to pin 10, 24V\_RET. The maximum current available is 40mA.

This supply can be used to power the inputs for interfacing the input system to a contact-closure type system. This supply may also be used for other purposes provided the current limit is not exceeded.

### **Input pin descriptions**

Pin 15, RMT\_ON: Issues START compressor command on RISING edge.

Pin 14, RMT\_OFF: Issues STOP compressor command on RISING edge.

Pin 13, RMT\_INTERLOCK: Disables operation of compressor when TRUE. Level sensitive.

Pin 12, RMT\_SLVL: While TRUE, changes the behavior of RMT\_ON (pin 15) to level sensitive, and RMT\_OFF to inactive.

### **Output pin descriptions**

Pins 7 and 8: Contact closed when all sensed parameter are within limits. Contact is open when operational error in compressor package is detected or warnings appear. Also open when line power is not on or either circuit breaker is off. All error type indications are latched and must be reset by front panel button or a start compressor request. Warnings are self-clearing if and when condition ceases to exist.

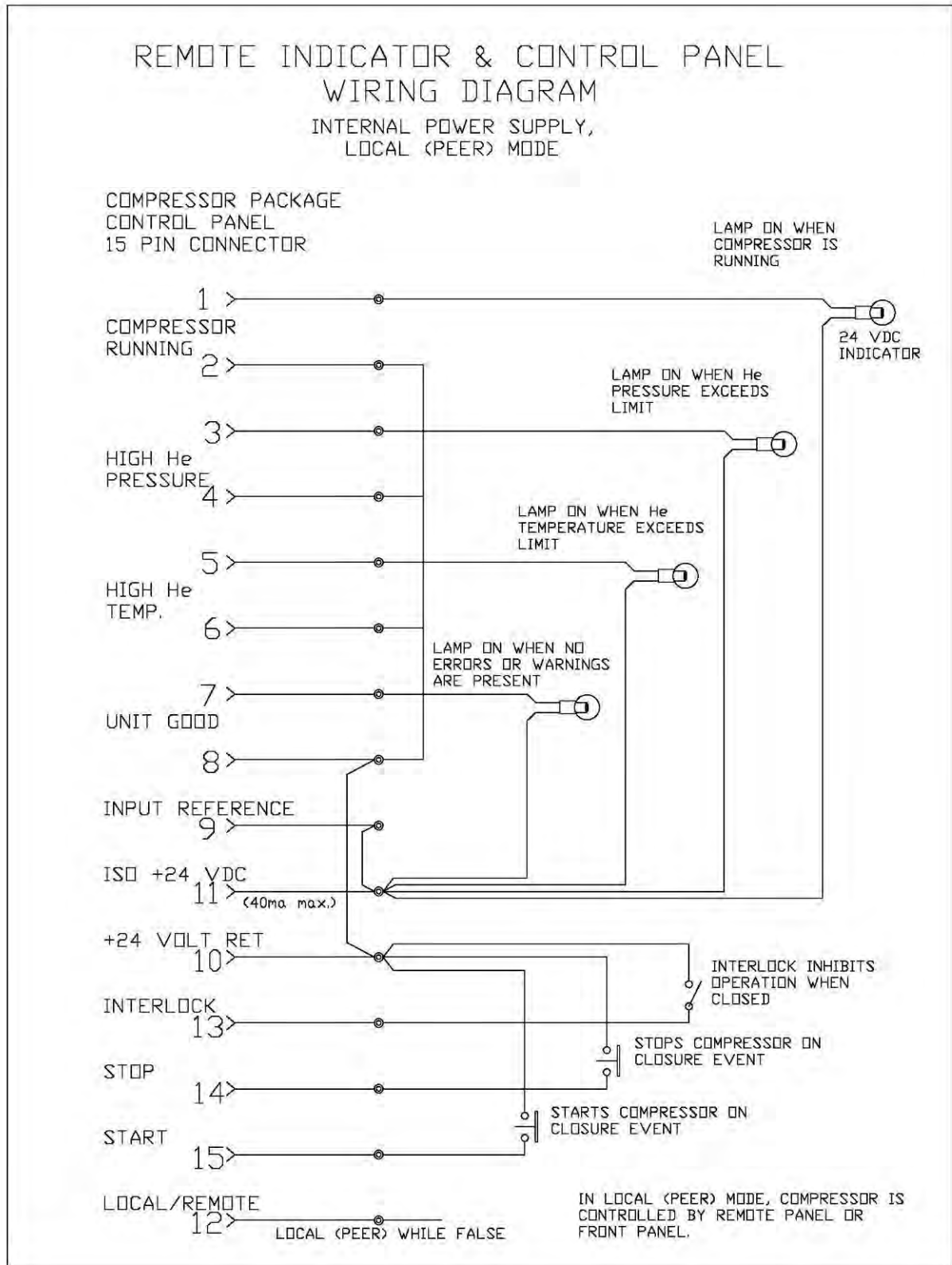
Pins 1 and 2: Contact closed while compressor module is running. Open otherwise.

Pins 5 and 6: Contacts closed when high helium temperature error condition is latched. Contacts open when the helium temperature drops to a certain level AND a compressor START or STOP event is issued. See Section 7 for temperature set points.

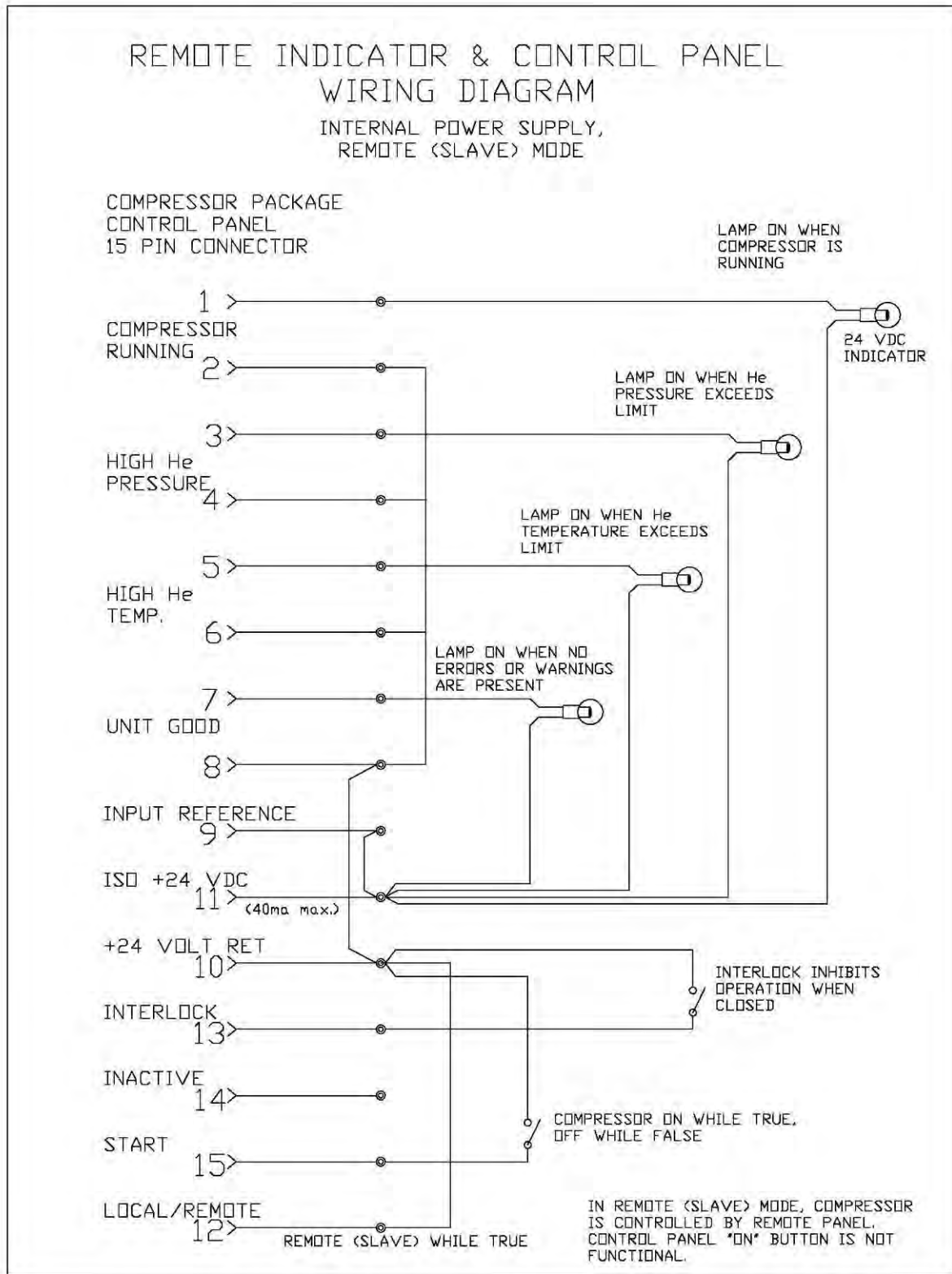
Pins 3 and 4: Contacts closed when high helium pressure error condition is latched. Contacts open when the helium pressure drops to a certain level AND a compressor START or STOP event is issued. See Section 7 for helium pressure set points.

**INFORMATION**

For more information on the System I/O 15 pin connector, refer to the *cm-db15.pdf* file. This file can be located on the ship disk that was sent with each system in the *Control Panel Computer Interface Package* folder. You can also download information from our website: <http://www.cryomech.com/filesare/>

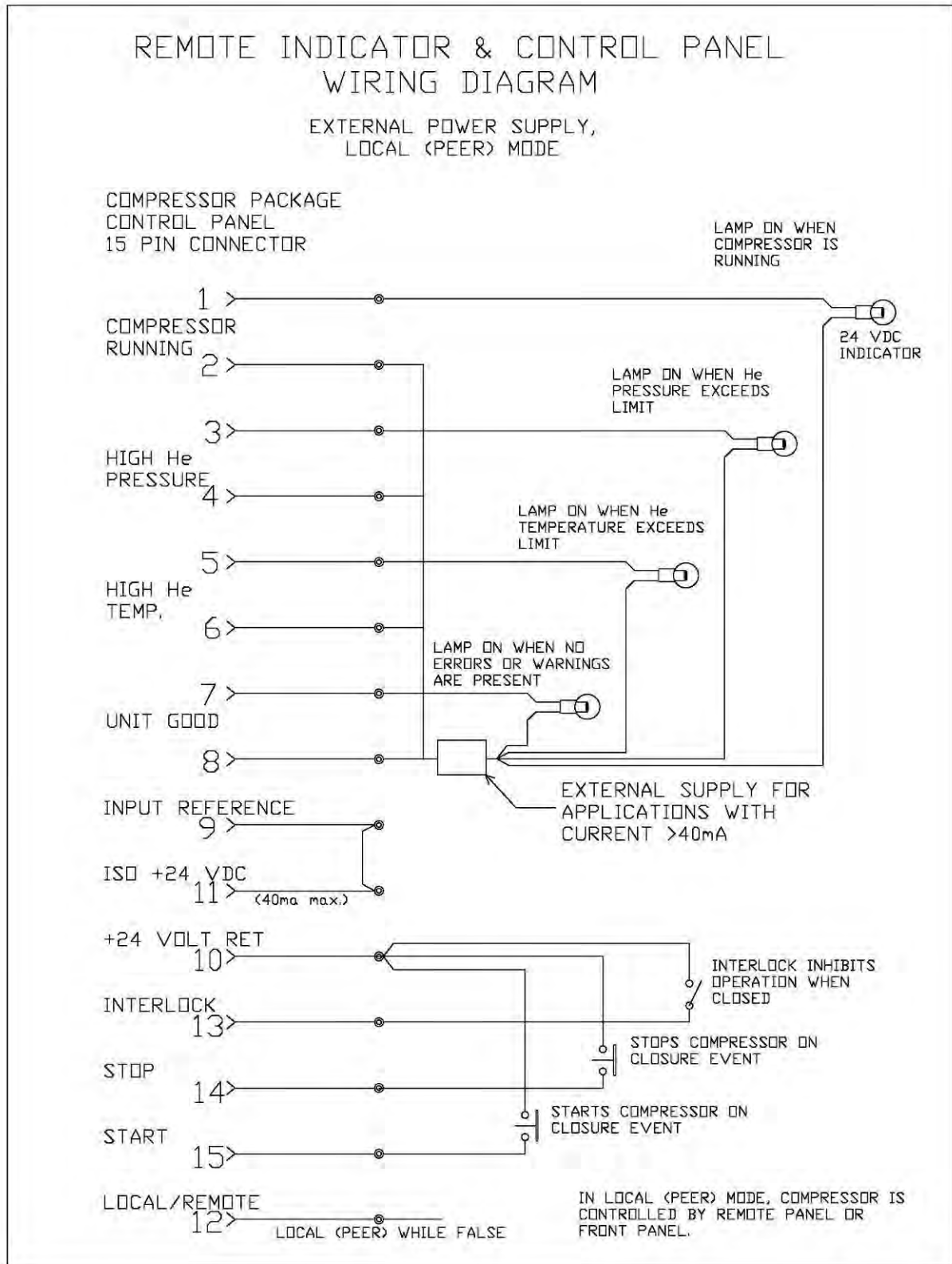


**Figure 5-8: System I/O wiring diagram – Internal Supply - Local Mode**

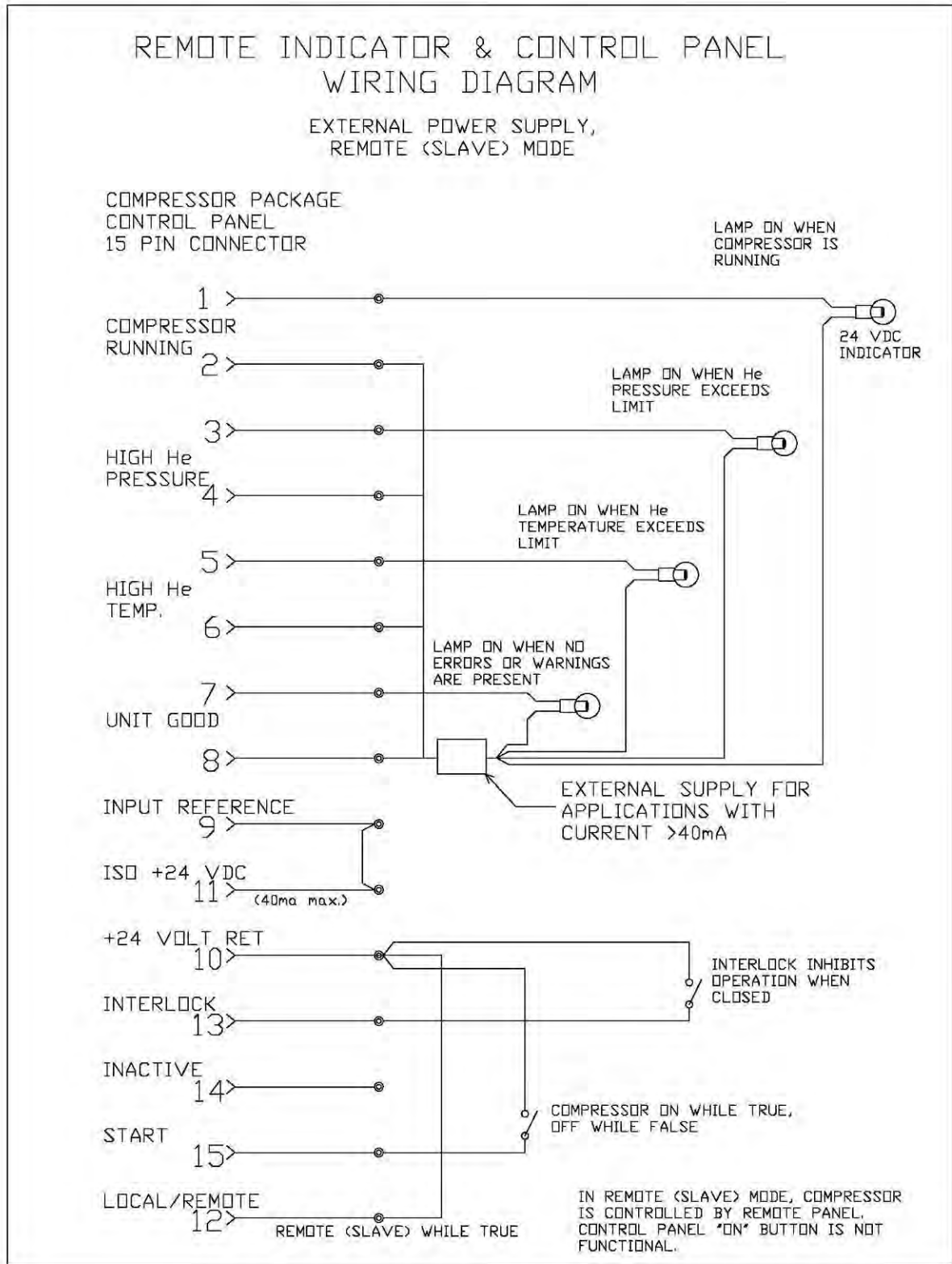


**Figure 5-9: System I/O wiring diagram – Internal Supply - Remote Mode**





**Figure 5-10: System I/O wiring diagram – External Supply - Local Mode**



**Figure 5-11: System I/O wiring diagram – External Supply - Remote Mode**

## 5.6 Description of the Pressure Controller



### **CAUTION**

**DO NOT** change settings of the pressure controller before reviewing this entire section. Changing these settings will cause the automatic operating system to malfunction. Pay close attention to **Section 5.6**

The dewar vapor pressure controller is used to monitor and control pressure in the dewar. A dewar pressure controller cable connects the pressure controller to the pressure transducer on the vapor return line. The controller is configured to add the heat necessary to maintain the internal pressure of the dewar within **0.125 PSIG** of the set point. This set point varies with operation mode, but always remains at positive pressure. This setting will eliminate the risk of operating the system under a vacuum in the dewar.

The controller has been programmed to monitor the pressure every 250 milliseconds. The heater power is updated every 250 milliseconds and the display is updated twice every second. Heater output is adjusted in small increments to maintain the pressure near the set point.



**Figure 5-12: Front panel of the pressure controller**

#### **A. Display Screen**

The Display Screen shows the current or active menu item. The default screen will show the current pressure inside the dewar/cryostat and heat load being applied in watts (W).

#### **B. Menu Button**

The Menu Button activates and toggles between the default screen and menus.

#### **C. Enter Button**

The Enter Button selects the current menu or confirms the selected setting. The enter button changes the selected setting.

#### **D. Up Arrow Button**

The Up Arrow Button is used to move the cursor up.

#### **E. Down Arrow Button**

The Down Arrow Button is similar to the up arrow button, however it moves in the opposite direction.

**F. Left & Right Arrow Button**

The Left and Right Arrow Button are similar to the up and down arrow button.

**J. Temperature Diode Receptacle**

The temperature diode receptacle is connected to a silicon diode mounted to the cold head's helium condenser inside the dewar. The diode cable connects to this receptacle and the diode connector on the cold head temperature monitor.

## Section 6

# Installation

## Section 6: Installation

### 6.1 Reliquefier installation

The entire section on the reliquefier installation should be reviewed before installing the reliquefier.



#### **CAUTION**

*Operating the Reliquefier in a magnetic field of greater than 500 gauss will void the warranty.*



#### **CAUTION**

*The Liquid Helium Return Line extending out of the side of the Helium Re-liquefier Main Assembly is extremely delicate. **Please handle with care. Do not bend or adjust without contacting Cryomech.*** The line is vacuum jacketed and constructed of very thin walled stainless steel tubing with very close tolerances.

#### 6.1.1 Inspect the Reliquefier

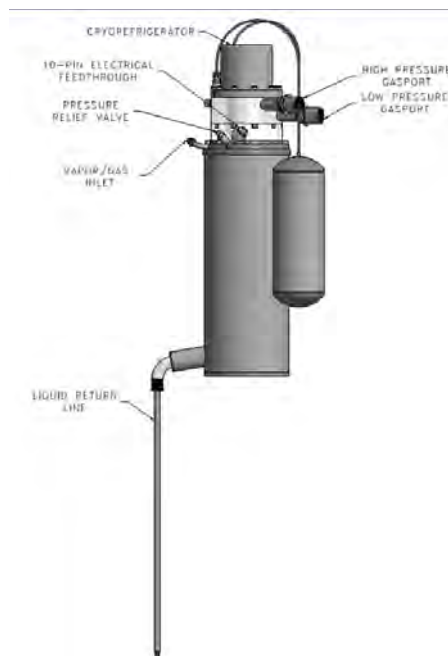


Figure 6-1: Representative schematic of a Reliquefier

- 1) Inspect the reliever for any damage to the liquid return line or main assembly.

Please notify Cryomech if scratches or dents are observed on any of the above-mentioned surfaces.

- 2) Make certain the flat gaskets are present and properly seated in the ends of the Aeroquip® connectors on the gasports.

## 6.2 Helium Reliever Installation into your cryostat



### NOTE

A liquid return line protector is attached to the Helium Re-liquefier assembly which is used for shipping, pre-installation, and storage purposes. It is wrapped in black and yellow caution tape for identification. Do not remove this until the Re-liquefier is ready to be lowered into the application. Do not is dispose of this part.

1. The Helium Re-liquefier must be mounted on an adjustable stand. If you have purchased the stand from Cryomech, Inc., please follow the installation instruction of the stand. If you choose to build your own stand, please use the 8 screw holes with 5/16-18 thread on the bottom of the main assembly for mounting (see attached drawing in Appendix A). The stand should be sufficient to hold the 75 lbs (34 kg), rigidly, with the liquid return line, perpendicular to the floor of the room.
2. Before the liquid helium return line is lowered into the fill port, carefully unscrew and remove the liquid return line protector as see in Figure 6-2. Save the liquid return line protector incase the re-liquefier is removed from the application. Extreme caution should be used when lowering or raising the liquid helium return line and precautions should be taken to ensure that the liquid helium return line is not bent as it enters into and resides in the fill port.

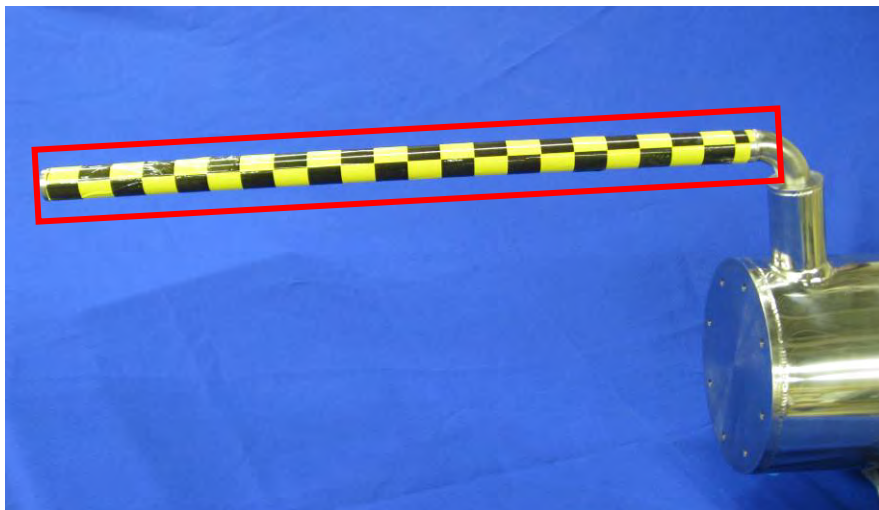
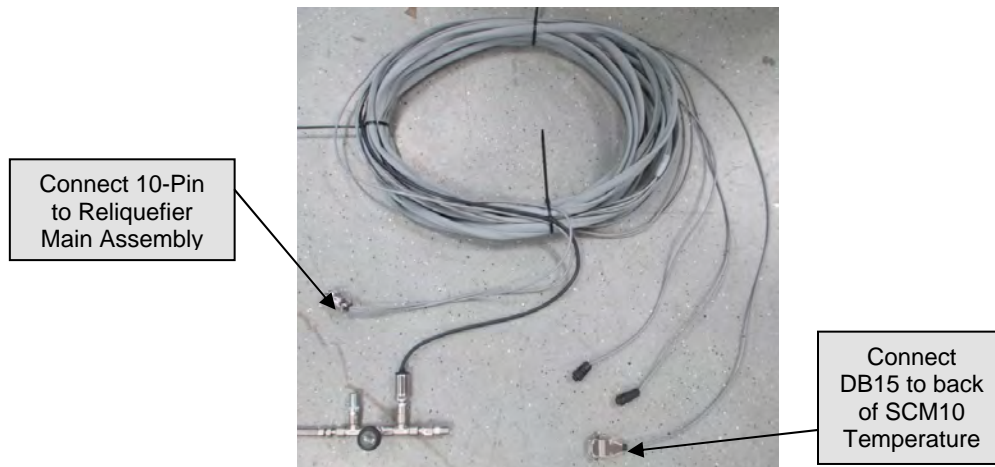


Figure 6-2: Liquid Return Line Protector

3. The return line has a larger diameter near the Re-liquefier Main Assembly at the bend radius and a smaller diameter to insert into the fill port (see Appendix A). To reduce the transfer losses in the liquid return line, the distance between the larger diameter and the return line sealing gland of the fill port should be less than 1".
4. After the fill port is inside the cryostat, attach the helium vapor Line to the cryostat and to the Re-liquefier Main Assembly. The helium vapor line is a 6 mm flexible line and shipped as a separate component. For optimum performance the helium Vapor Line should connect to the cryostat instrumentation neck so the helium vapor can be used to cool leads and shield according to the original design of the Dewar. The line comes with a an o-ring fitting to connect to the Re-liquefier Main Assembly and a needle valve. Cryomech has supplied the other end of the vapor line with an o-ring fitting and a 1/4 MNPT adapter fitting to connect to your dewar/cryostat. Confirm that the physical space containing the compressor package has an ambient temperature in the range 45 to 100°F (7 to 38°C).

### 6.3 Connecting the Temperature Monitor

The instrumentation cord connects the temperature sensor to the temperature monitor. The cord is completely wired and ready for use, as is shown in Figure 6-3.



**Figure 6-3: Instrumentation Cord**

1. Attach the female 10-pin connector to the male 10-pin receptacle on the Reliquefier Main Assembly.
2. Attach the male DB15 connector on the cord to the female DB15 connector on the back of the SCM10 temperature monitor See Figure 6-4.
3. Refer to the temperature monitor manual for start up and operation instructions.





Figure 6-4: Temperature Monitor

## 6.4 Connecting the Pressure Controller

The instrumentation cord also connects the condenser heater and pressure transducer to the pressure controller.

1. Connect the 3 pin male condenser heat connector to the 3-pin female heater output on the back of the HRC-110 pressure controller.
2. Connect the 4 pin male pressure transducer connector to the 4-pin female transducer input on the back of the HRC-110 pressure controller. See Figure 6-5
3. Refer to the pressure controller manual for start up and operation instructions.



Figure 6-5: Pressure Controller Back Panel

### 6.4.1 Set the Pressure Controller

If your cryostat boil off rate is smaller than the liquefaction rate of the re-liquefier, it is necessary to apply heat to the Pulse Tube condensing heat exchanger. This will ensure that the system pressure remains above atmospheric pressure. Cryomech recommends that you leave the pressure set point at 3psig. Please read the attached HRC-110 pressure controller manual for instructions on how to change this set point, if desired. The pressure controller heater output ships disabled. Enter the main menu and enable the heater output for pressure control.

## 6.5 Compressor installation

The entire section on compressor installation should be reviewed before installing the compressor package.

**CAUTION**

*Failure to follow these installation guidelines could result in voiding the warranty.*

**6.5.1 Prepare the compressor package location**

- Confirm that the physical space containing the compressor package has an ambient temperature in the range 45 to 100°F (7 to 38°C).
- Place the compressor package in a level position. For the compressor package to operate under optimal conditions, it must be oriented within 5° of being level.

**WARNING**

The compressor package must be positioned to provide easy access to the front-panel mounted circuit breaker.

- Position the compressor package so there is sufficient space around it for changing the adsorber. If the compressor package cannot be moved easily to an open area, leave approximately 2 additional feet (0.6 m) clearance above and to the left and right of it.

**6.5.2 Connect the water lines to the compressor****CAUTION**

Cooling water must meet the requirements in Section 5. *If water that does not meet the cooling water specifications in Section 5 is introduced into the system, even for cleaning purposes, it will void the warranty.*

**CAUTION**

Do not apply heat to the cooling water inlet and outlet connectors located on the front panel of the compressor.

- 1) Make sure that the cooling water supply is turned OFF.
  - Apply Teflon tape or pipe sealant to the threads on the male pipe thread (MPT) fittings that you provide to connect to the compressor's cooling water inlet connection and the cooling water outlet connection. The compressors require 3/8 MPT (3/8" Male National Pipe Thread) fittings.
- 2) Attach the fittings to the compressor's cooling water inlet and outlet connections. Turning the fitting clockwise, first hand-tighten the connection. Use a wrench to keep the compressor's cooling water connections from turning, and use another wrench to tighten fittings until snug.
- 3) Attach the supply water line to the *Cooling Water IN* fitting and the return water line to the *Cooling Water OUT* fitting.
- 4) Turn the cooling water supply ON and check for leaks.

- 5) Make certain the cooling water flow rate and inlet temperature meets the requirements in Section 5.

### 6.5.3 Connect the compressor package to the main power



#### **CAUTION**

A voltage deviation of more than 10% above or below the voltage rating can cause compressor motor overheating and possible failure. *Indications of operation outside that voltage range will void the compressor warranty.*

- 1) The system **MUST** be connected to a dedicated circuit breaker. The breaker must be mounted near the compressor package, within easy reach of the operator, and must be marked as the disconnecting device for the system. Specifications for circuit breakers vary according to the system's operating voltage. See the electrical specification tables in Appendix A for more information.
- 2) The compressor package comes with a main power cord attached. Assure that the length of the cord is sufficient to safely connect to the power source. If the cord is not sufficiently long, adjust the location of the compressor package.



#### **WARNING**

Be sure to follow all local electrical codes and guidelines.

- 3) Make sure that the dedicated circuit breaker is turned OFF.
- 4) The ground (or earth) wire in the power cord is either green (60 Hz systems) or green/yellow stripe (50 Hz systems). Connect the ground wire in the power cord to the ground (or earth) connector in the breaker panel, making sure to tighten the wire into the connector securely. It is important not to disable this wire.
- 5) Connect the remaining hot wires in the power cord to the corresponding lugs on the dedicated breaker in the breaker panel, making sure to tighten the connector securely. For 3 phase compressor packages, the order of the wires is not important at this time - correct order will be determined in Section 7.



#### **WARNING**

One lead of the compressor package is grounded. Never bypass this ground or attach the compressor package to an ungrounded circuit. A dangerous electrical hazard will develop.

### 6.5.4 Connect the helium flex lines to the cold head and the compressor package



#### **CAUTION**

Follow the procedure carefully when connecting and disconnecting the helium flex lines. Failure to follow the procedure can cause accidental coupling disassembly, destruction of the sealing O-ring, and helium loss.

**CAUTION**

Do not allow the flex lines to come into contact with corrosives or any type of commercial cleaning agent. *Helium leaks caused by exposure to corrosives or commercial cleaning agents will not be covered under warranty.*

**CAUTION**

Do not bend the flex lines to less than 10 inch (25 cm) radius or permanent damage may occur. *This type of damage is not covered under the warranty.*

- 1) Remove all dust caps and plugs from the helium flex lines, compressor package and cold head and place in tool kit. Save dust caps and plugs for future use.
- 2) Make certain the flat gaskets are present and properly seated in the compressor's and cold head's male Aeroquip® fittings.
- 3) With a dry, clean lint-free cloth remove any visible particles from the ends of all of the Aeroquip® couplings.

**IMPORTANT**

On some models, the high-pressure and low-pressure helium flex lines are not interchangeable due to the size of the Aeroquip® couplings attached to the ends of the flex lines. Before connecting the flex lines to the components, check the Aeroquip® couplings on the ends of lines to make certain they match the Aeroquip® couplings of the components.

- 4) With the wrenches supplied in the tool kit, connect a helium flex line to the low-pressure port on the compressor package front panel. See Figure 6-6. The low-pressure port is marked "Low." Tighten the connector until a positive stop is felt. *When attaching the Aeroquip® to the mating connector, make sure the threads are in alignment before you tighten the connector.*

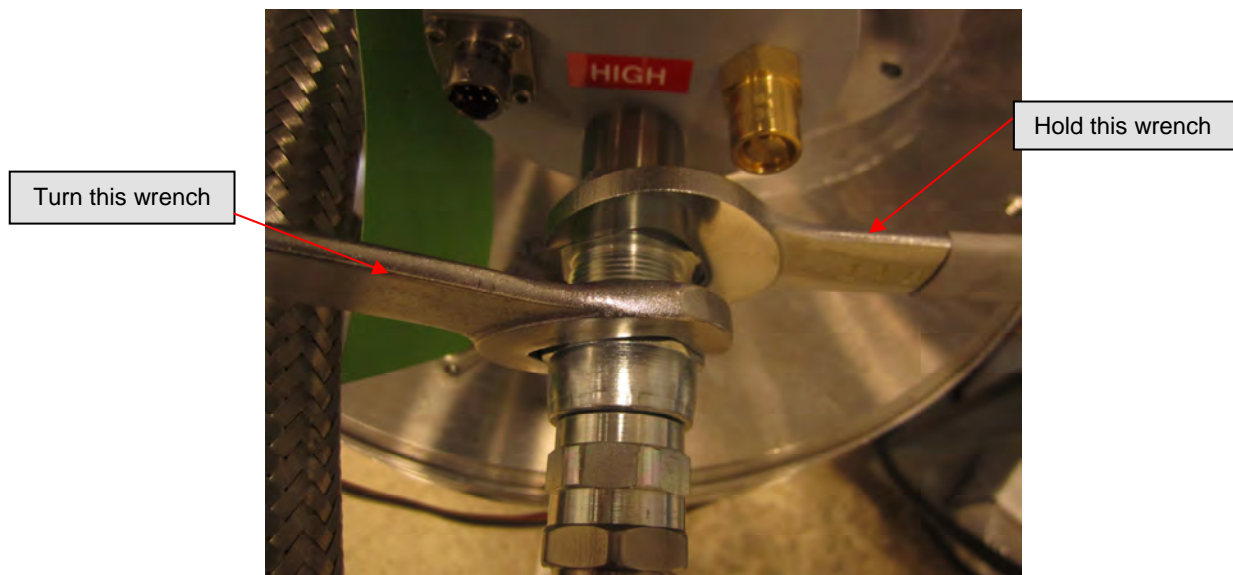
**IMPORTANT**

When connecting or disconnecting the flex lines, Cryomech recommends using a small amount of Teflon spray lubricant. A can of lubricant is included with each system. Before using the lubricant, you must read the instructions for its use. Instructions are packaged with the lubricant and included in Appendix B of this manual.



**Figure 6-6: Connecting the flex lines to a compressor package**

- 5) Connect the other end of the helium flex line to the low-pressure port on the cold head. The low-pressure port is marked "Low." Tighten the connector until a positive stop is felt.



**Figure 6-7: Connecting the high-pressure flex line to the high-pressure port on a cold head**

- 6) With the same wrenches, connect the other helium flex line to the high-pressure port on the compressor package front panel. The high-pressure port is marked "HIGH". Tighten the connector until a positive stop is felt.
- 7) Connect the other end of the helium flex line to the high-pressure port on the cold head. The high-pressure port is marked "HIGH". Tighten the connector until a positive stop is felt.



**WARNING**

Never remove the Aeroquip® couplings from the helium flex lines without first relieving the helium charge in the line to acceptable levels. The pressure in the hose can blow off the coupling with sufficient force to cause injury.

### 6.5.5 Connect the cold head motor cord

- 1) Note that the female plugs attached to each end of the cold head motor cord are unique for both the compressor and the cold head.
- 2) Assure that the cold head motor cord is sufficiently long to reach the cold head. *If the cord length is not sufficient to reach the cold head, adjust the location of the compressor package or the cold head.*
- 3) To connect the cold head motor cord to the cold head, make sure that the alignment pins on the receptacle correspond to the alignment grooves on the plug. Turn the plug sleeve clockwise while pushing the plug into the receptacle. The plug is designed to “click and lock” when assembly is completed.
- 4) To connect the cold head motor cord to the compressor, align the pins on the plug with the grooves on the compressor’s connector. Push the plug onto the connector and turn the locking ring clockwise until snug.

### 6.5.6 Remove excess helium from the compressor package



#### **IMPORTANT**

The system is shipped from the factory with excess helium in order to allow for some loss when assembling system components. Complete this step **ONLY** if the actual system pressure exceeds the pressure indicated in Step 1, below.

- 1) Observe both the low and high pressure gauges located on the front panel of the compressor package and determine which gauge has the lower reading. If the system helium pressure shown on the lowest reading gauge **EXCEEDS** the pressure specified in Appendix A follow the procedures in this step. Otherwise, skip this step and go to Section 7.
- 2) Assuming pressures **EXCEED** those indicated in Step 1, above, first make sure that the service valve (located on the front panel) is **CLOSED** (turned fully clockwise).
- 3) Attach the ¼" service Aeroquip® coupling to the service access.
- 4) Turning the service valve counter-clockwise, open the valve **SLOWLY**. Do not vent more than 5 PSIG (.34 bar / 34 kilopascals) of gas per minute.
- 5) Observe the gauge with the lower reading. Once the gauge reaches the system helium pressure indicated in Step 1, close the service valve by turning clockwise and remove the service Aeroquip® from the service access.

## Section 7

# Operation

## Section 7: Operation

### 7.1 Starting the system

#### 7.1.1 Checks before operating

- 1) Check the system pressure - the gauges should read the pressure specified in Appendix A.
  - o If the pressure is too high, vent some of the helium following the instructions in Section 6.
  - o If the pressure is too low, add helium following the instructions in Section 8.
- 2) Make sure the cold head motor cord is connected to both the compressor and the cold head.
- 3) Make sure the instrumentation cord is connected to both the Re-liquefier and the pressure controller.
- 4) Make sure all Aeroquip® couplings are securely fastened and the helium flex lines are oriented correctly.
- 5) Make sure the input power meets the specifications on the identification label.



#### **CAUTION**

A voltage deviation of more than 10% above or below the voltage rating can cause compressor motor overheating and possible failure. *Indications of voltage operation outside that range will void the compressor warranty.*

- 6) Make sure the flow rate and temperature range of the cooling water meet the requirements specified in Section 5.
- 7) Check that the dedicated circuit breaker is on.



#### **CAUTION**

*Operating the helium reliquefier in a magnetic field of greater than 500 gauss will void the warranty.*

#### 7.1.2 Startup procedure

- 1) Set the Pressure Controller
  - a. If your cryostat boil off rate is smaller than the liquefaction rate of the re-liquefier, it is necessary to apply heat to the Pulse Tube condensing heat exchanger. This will ensure that the system pressure remains above atmospheric pressure. Cryomech recommends that you leave the pressure setpoint at 3psig. Please read the attached HRC-110 pressure controller manual for instructions on how to change this set point, if desired. The pressure controller heater output ships disabled. Enter the main menu and enable the heater output for pressure control



- 2) Set Opening of the Needle Valve
  - a. The needle valve on the helium vapor line in Figure A-2 is used to control the natural convection flow within the Helium Re-liquefier.
  - b. Cryomech recommends that the needle valve is opened 2½ to 3 turns from the fully closed position. Cryomech has preset it for optimum performance with **our** test cryostat when there is liquid in the system. Minor adjustments might increase the liquefaction rate for your installation.
  - c. If ice forms on your vapor return line contact Cryomech for directions
- 3) Switch on the compressor package power at the MAIN circuit breaker. The RED OFF light will illuminate. After a few seconds the display will read J-mobile and the system will start to boot up, approximately a minute later the "Main Screen" will appear.
- 4) The compressor may be started by pushing the green "Compressor On" button, and stopped by pushing the black "Compressor Off" button.
- 5) If the front panel display indicates "3 Phase Power Improperly Wired" after pushing the "Compressor On" button, follow the instructions below.
- 6) Perform the following steps to correct the phase error in the compressor package:
  - a. Switch off the circuit breaker on the front panel of the compressor package.
  - b. Turn off the dedicated circuit breaker to disconnect the system from power at the source (to prevent electrical shock).
  - c. Examine the power cord and wire colors at the panel circuit breaker. Re-wire the input to the compressor by switching any 2 of the 3 input power wires.
  - d. Energize the breakers and press the "Compressor On" button. The compressor package should now operate properly.

## 7.2 Normal operation behavior

### 7.2.1 Normal Compressor pressures

On start up a pressure differential should be noticed immediately between the high and low pressure gauges. This differential will decrease as the cold head cools down.

The typical pressure differential is approximately 220 to 250 PSI (15.2 to 17.2 bar / 1520 to 1720 kilopascals) with a 5 to 10 PSI (.34 to .7 bar / 34 to 70 kilopascals) bounce on the pressure gauge needles.

Actual operating pressures at various cold head temperatures are recorded on the Cold Head Performance Table that is included with the cold head.

### 7.2.2 Normal sounds

When operating properly, the cryorefrigerator will emit a rhythmic squeak or chirp. This noise is an indication of the proper flow of helium gas within the system.

### 7.2.3 Cool Down Time

The Helium Re-liquefier will cool down to 4.2K from room temperature and begin condensing helium in approximately 4 hours

### 7.3 Use of the display panel

Status and error messages will be shown on the display screen. The status messages, error messages, and set points at which error conditions will occur are listed in Section 7.7.

The screen normally shown on the display is referred to as the “Main Screen”. The messages described in Section 7.7 are displayed on the bottom of the run-time screen. The bottom line on the main screen displays the number of hours the compressor has run.

The “Menu” button in the bottom left corner of the main screen is used to switch navigate between all of the various screens available.

### 7.4 Shutdown procedure

Press the black compressor “Off” button on the front panel of the compressor package. This will switch off the compressor system. Switch off the front-panel mounted circuit breakers to shut down the entire system.

### 7.5 Recommended routine procedures



#### **INFORMATION**

It is helpful to monitor the cryorefrigerator daily in order to detect changes in performance early. These changes can signify degradation in performance that could result from the beginning of a problem that requires attention.

Cryomech recommends keeping regular logs of key measurements at intervals that make sense for the way you use your system.

#### 7.5.1 High and low pressure

Changes in the high and low pressure readings on the compressor package’s gauges are used for diagnosing several different types of problems. It is important to know whether changes are sudden or gradual and to know how the high and low pressures are changing relative to each other.

The high and low pressures should be monitored daily.

Cryomech recommends that you maintain a regular record, at intervals that make sense for the way you use your system, of the high and low pressure readings. The RS232/488 port can be used to remotely monitor and record the pressure data.

#### 7.5.2 Cold head temperature

Temperature changes are the other key diagnostic.

If a temperature sensor is attached to the cold head’s heat exchanger(s), Cryomech strongly recommends that you monitor the temperature(s) daily.

Cryomech also recommends that you keep a regular record of the temperature(s) at intervals that make sense for the way you use your system.

### 7.5.3 Cooling water input and output

If possible, Cryomech recommends keeping a regular record of the input and output cooling water temperatures and of the cooling water flow rate. The RS232/488 port can be used to remotely monitor and record the water temperature data.

## 7.6 Disassembling the system for transport or storage

Use the following steps to prepare a Cryomech Reliquefier for eventual transport or storage.

- 1) Make sure that the display on the front panel indicates that the compressor system is OFF.
- 2) Disconnect the power to the system by switching the front panel breakers to the OFF position
- 3) Disconnect the main power to the system by switching the dedicated circuit breaker to the OFF position.
- 4) Disconnect the power cord from the external breaker panel. Coil up the power cord in preparation for transport or storage.
- 5) Disconnect the cold head motor cord from the cold head and from the compressor. Coil the cold head motor cord in preparation for transport or storage.
- 6) Disconnect the instrumentation cord from the reliquefier.
- 7) Turn off the water supply at the source.
- 8) Using two wrenches disconnect the supply and return water lines from the inlet and outlet fittings by turning the fittings counter-clockwise until they are released from the fittings. Store the connectors for transport or storage.
- 9) Drain the water from the compressor package. Blow remaining water out with compressed air.



### **IMPORTANT**

Do not continue with the remaining steps until the cold head temperature has risen above 150K. If the cold head is disconnected from the system while below 150K, helium will expand within the cold head as it warms, escape through the pressure relief valve and require the user to recharge the system with helium before it would again operate properly.

- 10) Using the wrenches supplied in the tool kit, disconnect the high and low pressure flex lines from the compressor package by turning the Aeroquips® counter-clockwise with one wrench while holding the other wrench to prevent the flex line from twisting. See Figure 7-1.

**IMPORTANT**

When connecting or disconnecting the flex lines, Cryomech recommends using a small amount of Teflon spray lubricant. A can of lubricant is included with each system. Before using the lubricant, you must read the instructions for its use. Instructions are packaged with the lubricant and included in the Appendix of this manual.



**Figure 7-1: Disconnecting flex lines from a compressor package**

- 11) Disconnect the Aeroquips® on the high and low pressure fittings on the cold head by turning the flexible line's Aeroquip® counter-clockwise with one wrench while holding the cold head's Aeroquip® with the other wrench. See Figure 7-2.



**Figure 7-2: Disconnecting flex lines from a cold head**

- 12) Install the dust plugs (that originally came with the system and are stored in the tool kit) on the female Aeroquip® couplings attached to the helium flex lines.
- 13) Install the dust caps on the male Aeroquip® fittings located on the compressor package and the cold head.
- 14) Remove the reliquefier from its mounting stand, taking extra care not to damage the liquid helium return line.
- 15) Once removed, replace the Liquid return line protector and place the reliquefier in the original packaging container.
- 16) Recoil the helium flex lines and prepare for transport or storage.
- 17) Assure that all components are stored in appropriate containers and location.

## 7.7 Troubleshooting

### 7.7.1 System will not start

<b>SYMPTOM</b>	System will not start.
<b>POSSIBLE CAUSE</b>	<ol style="list-style-type: none"> <li>1) No power supplied to the compressor package.</li> <li>2) Circuit breakers off.</li> <li>3) "Compressor Error" message displayed on display screen.</li> </ol>
<b>REMEDY</b>	<ol style="list-style-type: none"> <li>1) Check the power supply to the system and verify that it meets the requirements outlined in Section 5.</li> <li>2) Make certain both circuit breakers, located on the front panel of the compressor package, are on.</li> <li>3) Refer to Section 7.7.5 for error message diagnostics.</li> </ol>

### 7.7.2 System starts, no pressure fluctuation

<b>SYMPTOM</b>	System starts, no bounce in the pressure gauges, no refrigeration.
<b>POSSIBLE CAUSE</b>	<ol style="list-style-type: none"> <li>1) Cold head motor cord not connected to the cold head and/or to the compressor package.</li> <li>2) Aeroquip® connector(s) not completely tightened.</li> <li>3) High and low pressure helium flex lines reversed.</li> </ol>
<b>REMEDY</b>	<ol style="list-style-type: none"> <li>1) Turn off the compressor and connect the cold head motor cord to the cold head and/or to the compressor package.</li> <li>2) Tighten all Aeroquip® connectors.</li> <li>3) Verify that one of the helium flex lines connects the high pressure port on the compressor package to the high pressure port on the cold head and that the other helium flex line connects the low pressure ports.</li> </ol>

**7.7.3 System has shut itself down**

<b>SYMPTOM</b>	System has shut itself down.
<b>POSSIBLE CAUSE</b>	<ol style="list-style-type: none"> <li>1) Circuit breaker tripped.</li> <li>2) Interruption of the power supply to the compressor package.</li> <li>3) "Compressor Error" message displayed on front panel screen.</li> </ol>
<b>REMEDY</b>	<ol style="list-style-type: none"> <li>1) Reset the circuit breaker on the front panel of the compressor package.</li> <li>2) Check the power supply to the system and verify that it meets the requirements outlined in Section 5.</li> <li>3) Refer to Section 7.7.5 for error message diagnostics.</li> </ol>

**7.7.4 Run time display screen description**

Run time messages are displayed on the main display screen. The number of hours the system has operated is displayed in the bottom right hand corner.

<b>Top line message on the display screen</b>	<b>Message description</b>
"Idling..."	Front panel or remote interface turned off compressor. All is well.
"Running Normally"	Compressor is running. All is well.
"Starting..."	Compressor ON request received, and compressor will start within 10 seconds unless an error occurs or a stop request is received.
"Helium Over Temp Recovery Delay.... WAIT x"  (x is a number, counting down, in minutes & seconds. When x is zero compressor will start)	Compressor ON request received and compressor will be able to be restarted in x amount of time unless an error occurs or a stop request is received. This message will show when the compressor has encountered certain errors that require a minimum off time, such as "Helium Temp. too high"
"You have had 6 errors in less than an hour: mm:ss"  mm:ss indicates them minutes : seconds until the compressor can be reset.	The compressor has entered a locked-out state due to experiencing 6 errors within one hour. The compressor cannot be restarted until the error lockout has been reset. You must select the lockout menu and reset the number of lockouts. In doing this you must acknowledge the relevant errors and therefore take the necessary steps to prevent these errors from reoccurring. Resetting the lockout status will enforce a 30 min cool down period before the compressor can be restarted to prevent the short-cycling of compressor module. The lockout contributors are noted in Section 7.6.5.

### 7.7.5 Error diagnostics on display screen

Errors will cause the compressor system to stop. Errors are displayed on the bottom line of the display screen. If more than one of the errors below is present, only the highest priority one will be displayed. The table lists errors from highest to lowest priority. If the error is a lockout contributor, it will be noted in the Explanation column.

Once the error condition has cleared, the compressor can be restarted by pressing the Compressor ON button.

If the error condition still exists the compressor will not restart.

Error Message	Explanation
"High pressure too High!"	The high side pressure is above the high set point. Release helium from the system.
"High pressure too Low!"	The high side helium below the low set point. Add helium to the system.
"Low Pressure Too Low!"	The helium gas pressure is below the threshold. Add helium to the system.
"Low Pressure Too High!"	The low side helium pressure is above the high set point; release helium from the system, verify line orientation (lines may be reversed High to Low.)
"Delta Pressure Too High!"	The differential pressure is above the high set point; verify static pressure.
"Delta Pressure Too Low!"	The differential pressure is below the low set point verify static pressure; verify line orientation (lines may be reversed High to Low.)
"Static Pressure Too High!"	The static pressure is above the high set point; verify static pressure, release helium
"Static Pressure Too Low!"	The static pressure is below the low set point; verify static pressure, add helium
"Water In Temp Too High"	The inlet water temperature is above the high set point; reduce water temperature
"Water In Temp Too Low"	The inlet water temperature is below the low set point; increase water temperature
"Water Out Temp Too High!"	The outlet water temperature is above the high set point; increase water flow rate and/or reduce temperature.
"Water Out Temp Too Low"	The outlet water temperature is below the low set point; increase water temperature.
"Helium Temp Too High!"	The helium gas temperature is above the high set point; check cooling water flow rate/temperature, check compressor module oil level by checking sight glass when the compressor is running.
"Helium Temp Too Low!"	Helium discharge temperature below the low set point; check cooling water temperatures, increase ambient temperature if system has been off and ambient temperature is below 40°F
"Oil Temp Too High!"	The oil temperature is above the high set point; Check flow rate and inlet temperature of cooling water.

"Oil Temp Too Low!"	The oil temperature is below the low set point; check cooling water temperatures, increase ambient temperature if system has been off and ambient temperature is below 40°F
"Compressor Motor Current Too Low!"	This occurs when the compressor module motor current is below threshold while the motor is requested running. Can be caused by an overheated compressor module.
"You have had 6 errors in less than an hour: MM:SS"	The compressor is in lockout mode due to more than 6 errors within one hour; the compressor cannot be started until 30 minutes has elapsed, and the lockout has been reset using the reset button. MM:SS indicates minutes : seconds remaining until compressor can be restarted
"3 Phase Power Improperly Wired!"	The order of the phase power is wrong. Re-wire the input to the compressor by switching any 2 of the 3 input power wires.
"Power Supply Error!"	Power supply has exhibited a fault, verify voltage output or contact Cryomech

### 7.7.6 Warning diagnostics on display screen

Warnings do not cause the compressor to stop and do not prevent the compressor from starting. If more than one of the warnings below is present, only the highest priority one will be displayed.

Warning Description	Explanation
"High Pressure Running High!"	High pressure is approaching high set point, if the warning does not go away after the cold head cools down, verify that static pressures are correct and all lines are connected completely.
"High Pressure Running Low!"	High pressure is approaching the low set point; verify static pressure, check historical data to determine if a leak may have occurred.
"Low Pressure Running Low!"	Low pressure is approaching the low set point; verify static pressure, check historical data to determine if a leak may have occurred.
"Low Pressure Running High!"	Low pressure is approaching the high set point; Flex lines may be reversed check orientation of lines, verify that the high pressure is greater than the low pressure
"Delta Pressure Running High!"	Differential pressure approaching high set point; this condition may occur on initial startup. Under normal operation it will reduce as the cold head begins to cool down. If not check static pressure and flex line connections
"Delta Pressure Running Low!"	Differential pressure approaching low error set point; flex lines may be reversed
"Static Pressure Running High!"	Static pressure approaching high error set point; verify required static pressure before starting the compressor
"Static Pressure Running Low!"	Static pressure approaching low error set point; verify required static pressure before starting the compressor
"Water In Temp Running High"	Water inlet temperature is approaching high error set point; reduce inlet water temperature or increase flow rate to prevent overheating
"Water In Temp Running Low"	Water inlet temperature is approaching low error set point; increase inlet water temperature or reduce flow rate to prevent overcooling or overheating caused by reduced oil temperature
"Water Out Temp Running High!"	Water outlet temperature is approaching high error set point; reduce inlet water temperature or increase flow rate to prevent overheating



"Water Out Temp Running Low"	Water outlet temperature is approaching low error set point; increase inlet water temperature or reduce flow rate to prevent overcooling or overheating caused by reduced oil temperature
"Helium Temp Running High!"	Helium discharge temperature approaching high error set point; check cooling water temperatures, may also be caused by low oil level - check compressor module sight glasses or low oil temperature caused by cool water
"Helium Temp Running Low!"	Helium discharge temperature running low; check cooling water temperatures, increase ambient temperature if system has been off and ambient temperature is below 45°F
"Oil Temp Running High!"	Oil temperature approaching high error set point; verify cooling water flow and temperatures
"Oil Temp Running Low!"	Oil temperature approaching low error set point; verify cooling water flow and temperatures (reduce flow rate or increase temperature)

### 7.7.7 Error and warning set points

The trip and clear set points for all the errors and warnings are listed in the following table.

Error Message	Lock Out Contributor?	Trip	Clear
"High pressure too High!"	YES	400 PSIG (27.6bar)	375 PSIG (25.9 bar)
"High pressure too Low!"	YES	150 PSIG (10.3bar)	170 PSIG (11.7 bar)
"Low Pressure Too Low!"	YES	40 PSIG (2.8 bar)	50 PSIG (3.4 bar)
"Low Pressure Too High!"	YES	250 PSIG (17.2 bar)	240 PSIG (16.5 bar)
"Delta Pressure Too High!"	YES	300 PSIG (20.7bar)	290 PSIG (20bar)
"Delta Pressure Too Low!"	YES	50 PSIG (3.4 bar)	75 PSIG (5.2 bar)
"Static Pressure Too High!"	YES	300 PSIG (20.7 bar)	280 PSIG (19.3 bar)
"Static Pressure Too Low!"	YES	100 PSIG (6.9 bar)	170 PSIG (11.7 bar)
"Water In Temp Too High"	YES	110°F (43°C)	80°F (27°C)
"Water In Temp Too Low"	YES	40°F (4°C)	50°F (10°C)
"Water Out Temp Too High!"	YES	125°F (52°C)	110°F (43°C)
"Water Out Temp Too Low"	YES	40°F (4°C)	50°F (10°C)
"Helium Temp Too High!"	YES	190°F (88°C)	120°F (49°C)
"Helium Temp Too Low!"	YES	40°F (4°C)	50°F (10°C)
"Oil Temp Too High!"	YES	125°F (52°C)	110°F (43°C)
"Oil Temp Too Low!"	YES	40°F (4°C)	50°F (10°C)

"Compressor Motor Current Too Low!"	YES	< 5A	≥ 5 A
"You have had 6 errors in less than an hour: MM:SS"	no	>6 errors (lock out contributors) in <1 hour	30 minute delay, manual restart
"3 Phase Power Improperly Wired!"	no	Phase sequence incorrect	Phase sequence correct
"Power Supply Error!"	no	Power supply fault	Power supply non-fault

<b>Warning Description</b>	<b>Trip / Clear</b>
"High Pressure Running High!"	375 PSIG (25.9bar)
"High Pressure Running Low!"	170 PSIG (11.7bar)
"Low Pressure Running Low!"	50 PSIG (3.4 bar)
"Low Pressure Running High!"	240 PSIG (16.5 bar)
"Delta Pressure Running High!"	290 PSIG (20.0bar)
"Delta Pressure Running Low!"	75 PSIG (5.2 bar)
"Static Pressure Running High!"	280 PSIG (19.3 bar)
"Static Pressure Running Low!"	170 PSIG (11.7 bar)
"Water In Temp Running High"	85°F (29°C)
"Water In Temp Running Low"	45°F (7°C)
"Water Out Temp Running High!"	110°F (43°C)
"Water Out Temp Running Low"	45°F (7°C)
"Helium Temp Running High!"	170°F (77°C)
"Helium Temp Running Low!"	45°F (7°C)
"Oil Temp Running High!"	120°F (49°C)
"Oil Temp Running Low!"	45°F (7°C)

## 7.8 Contact Cryomech with Questions

It is hoped that the Operations Section of this manual has helped you to obtain satisfactory results in the use of your cryorefrigerator. While the information offered should facilitate set up and operation, you may have a special situation that requires further considerations. If after reading the Operations Section, you still have questions, contact Cryomech for further information.

### 7.8.1 Contact Information

Cryomech, Inc.  
113 Falso Drive

Syracuse, NY 13211

Phone: (315) 455-2555

Fax: (315) 455-2544

Email: [cryoservice@cryomech.com](mailto:cryoservice@cryomech.com)

Website: [www.cryomech.com](http://www.cryomech.com)

## Section 8

# Routine Maintenance

## Section 8: Routine Maintenance

### 8.1 Introduction

This section contains basic, essential maintenance information. For more detailed information, contact Cryomech.

### 8.2 Maintenance schedule

Maintenance	Frequency	Comment
Replace adsorber	Every 20,000 hours	See Section 8.4
Vent helium gas	As required	See Section 8.5
Charge helium gas	As required	See Section 8.6
Clean air filters (air cooled only)	As required	Washable filters

### 8.3 Reliquefier/Cold head



#### **CAUTION**

The helium reliquefier contains no user-serviceable parts. *Attempting to disassemble the helium reliquefier will void the warranty.*

CONTACT CRYOMECH IF THE HELIUM RELIQUEFIER NEEDS TO BE RETURNED FOR SERVICING.

### 8.4 Replace the adsorber

#### Required tools:

Quantity	Description	Comment
1	1" Open end wrench	For Aeroquip® coupling
1	1-1/8" Open end wrench	For Aeroquip® coupling
1	1-3/16" Open end wrench	For Aeroquip® coupling
1	1-3/8" Open end wrench	For Aeroquip® coupling
1	1-5/8" Open end wrench	For Aeroquip® coupling
1	Slotted screwdriver	For hose clamp
1	Phillips head screwdriver	For side panel of compressor



#### **CAUTION**

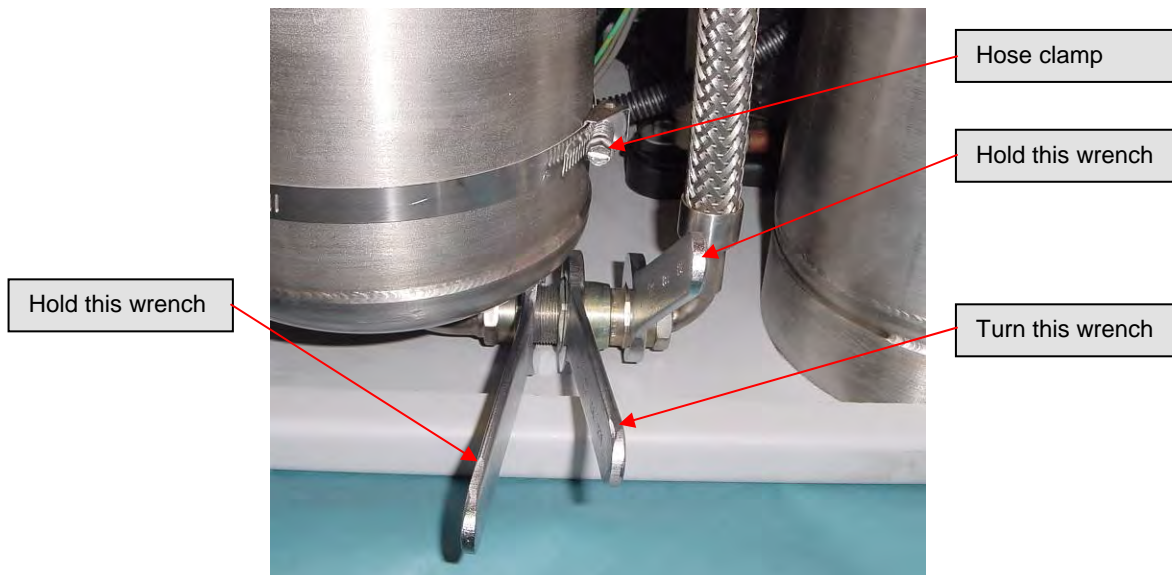
At no time should the Aeroquip® couplings be removed from the adsorber when replacing the adsorber. Replacement can be completed without relieving system pressure since the adsorber is equipped with Aeroquip® couplings for sealed removal.

- 1) Shut down the system by pressing the OFF button, then switching the helium compressor package circuit breakers off, and disconnecting the input power from the compressor package.

**WARNING**

The input power must be disconnected from the helium compressor package before removing any helium compressor package panels.

- 2) Disconnect both helium flex lines from the compressor.
- 3) Remove the side panel from the right hand side of the compressor package.
  - a. Remove the 6 quarter-turn screws that hold the cover on and retain them.
  - b. Pull the panel away from the compressor package.
- 4) Using three wrenches disconnect the Aeroquip® coupling between the adsorber and the oil separator as shown in Figure 8-1.



**Figure 8-1: Disconnecting the Aeroquip® adsorber**

- 5) Remove the nut holding the high-pressure Aeroquip® coupling to the front panel.
- 6) Loosen and disconnect the hose clamp that attaches the adsorber to the front panel.
- 7) Remove the adsorber from the compressor package.
- 8) Check the Aeroquip® couplings for oil residue. If oil is present, contact Cryomech for further assistance.
- 9) Remove the lock washer from the top Aeroquip® and install it on the new adsorber.
- 10) To install the new adsorber, reverse steps 4 through 7.
- 11) Reconnect both helium flex lines to the compressor.
- 12) Reattach the cover or side panel to the compressor package.

## 8.5 Vent excess helium

**Required tools:**

Quantity	Description	Comment
1	3/4" Open end wrench	For Aeroquip® coupling
1	Service Aeroquip® coupling	For service access port



**CAUTION**

Venting more than 5 PSIG (.34 bar / 34 kilopascal) of helium per minute will lead to improper oil migration within the system. If this condition occurs, factory service will be required.

This procedure should only be used to vent small quantities of helium from an overcharged system.

- 1) Make sure the service valve is closed. See Figure 8-2.
- 2) Attach the small service Aeroquip® coupling to the service access port.
- 3) Open the service valve slowly. Do not vent more than 5 PSIG (.34 bar / 34 kilopascal) of helium per minute.
- 4) After venting the helium, close the service valve and remove the service Aeroquip® from the service access port.

## 8.6 Recharge helium

**Required tools and equipment:**

Quantity	Description	Comment
1	3/4" Open end wrench	For Aeroquip® coupling
1	Service Aeroquip® coupling	For service access port
1	Vacuum/charging station	For adding helium



**CAUTION**

When adding helium, the helium must be 99.999% pure. Contamination by other gases will result in the freezing of the contaminant gases in the cold head because their freezing temperature is much higher than that of helium. Contaminants in the helium charge will severely degrade the cold head's function and it will require factory servicing.

*Contamination of the helium by other gases is a common cause of premature failure and, unless resulting from a system failure, is not covered by the warranty.*

This procedure should be performed with the compressor package shut down. Adding helium is possible whether or not the cold head is attached to the compressor package. Both the service access and service valve are connected to the low-pressure manifold of the compressor.

- 1) Turn the system off.
- 2) Allow the entire system, both the compressor package and the cold head, to come to room temperature.
- 3) Use only high purity helium with a minimum purity of 99.999%.
- 4) Check that the helium source and regulator are capable of pressurizing to the desired pressure.
- 5) Make sure the service valve is closed.
- 6) Attach the service Aeroquip® coupling to the service access port.

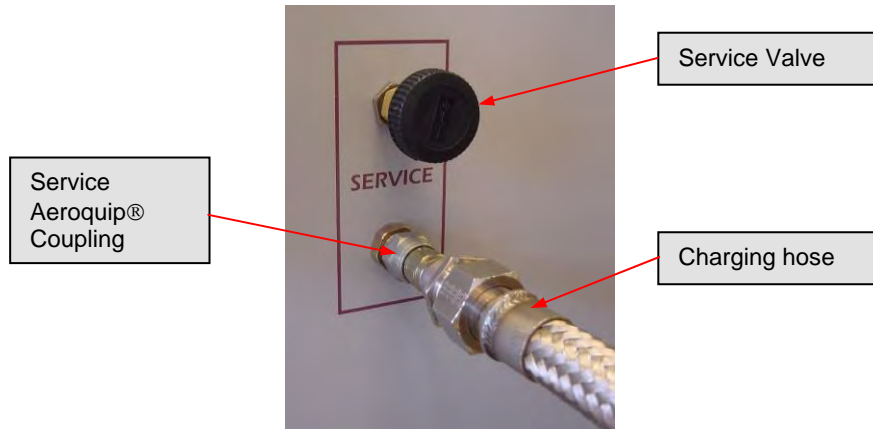


Figure 8-2: Service valve and access port

- 7) Attach a charging line from the service Aeroquip® to a typical vacuum/charging system as shown in Figure 8-3 and Figure 8-4 below.

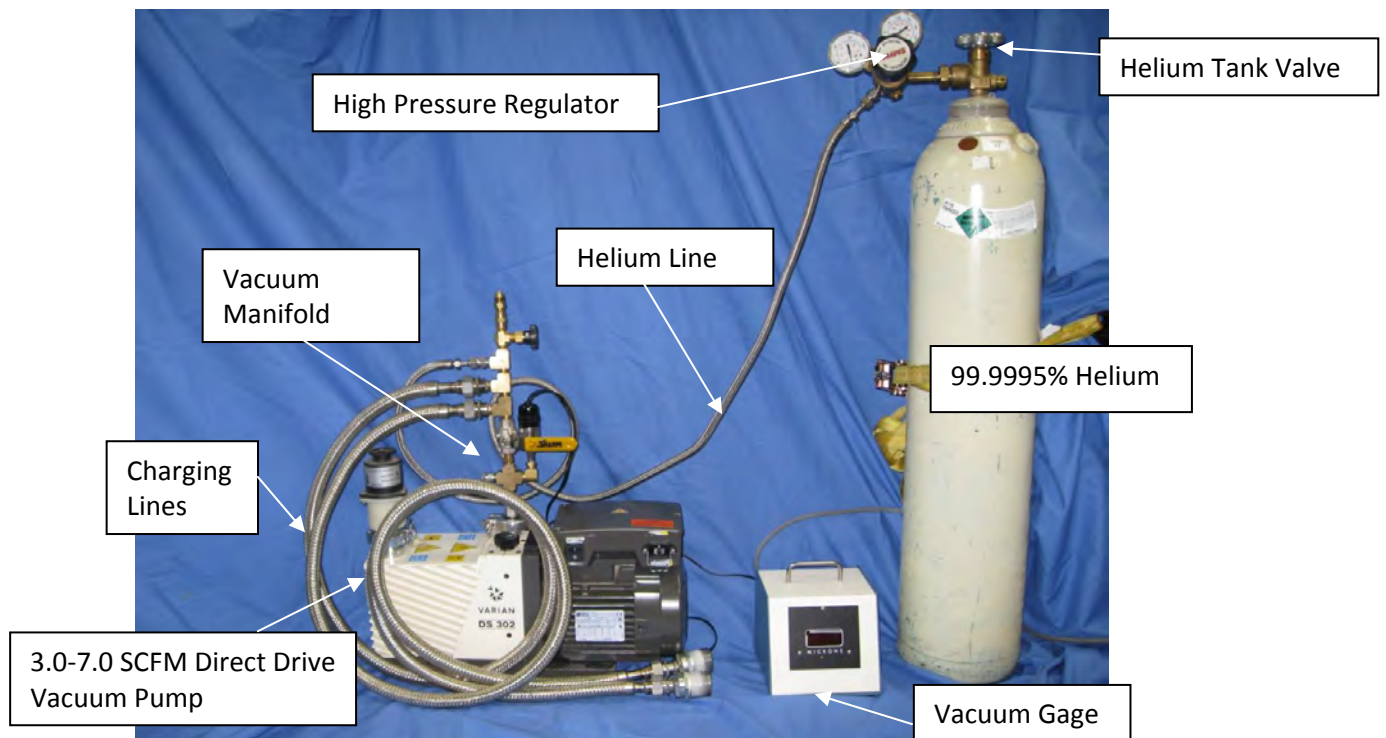
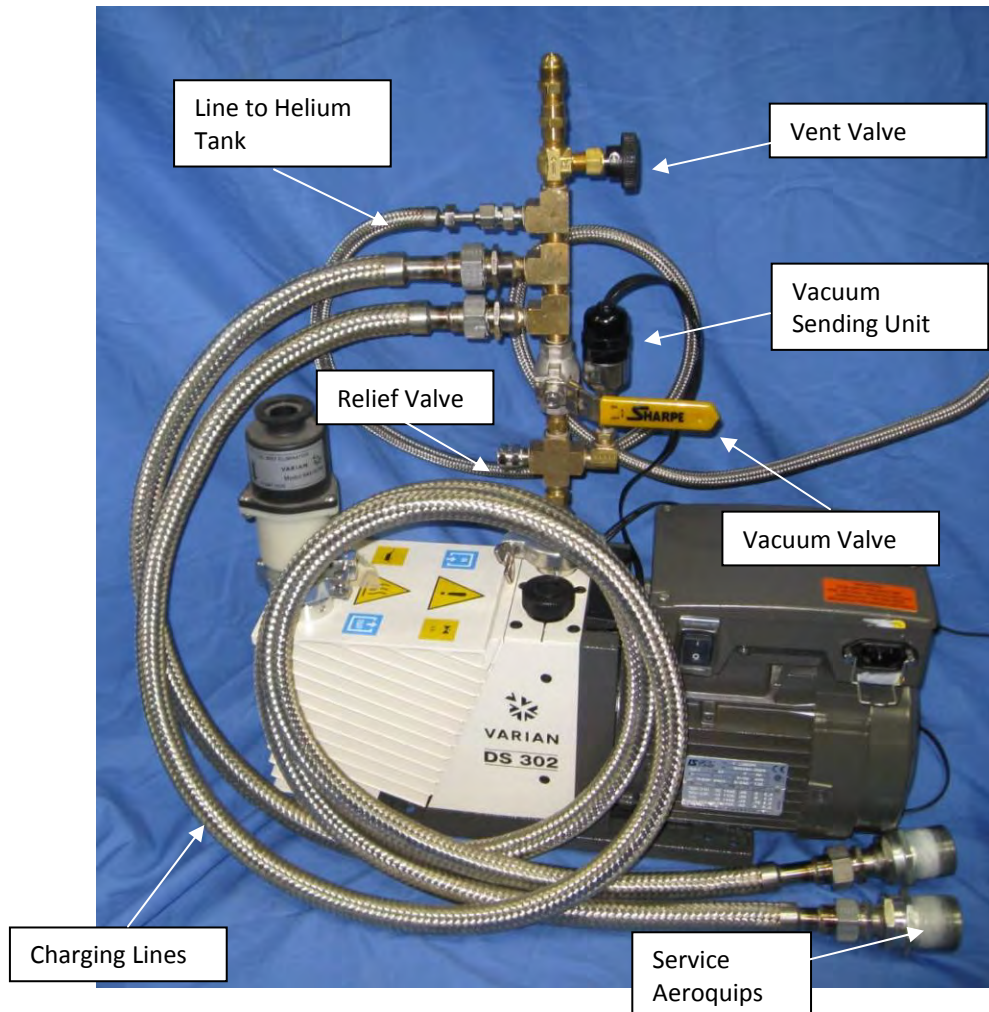


Figure 8-3: Vacuum/charging system





**Figure 8-4: Close up of vacuum/charging manifold and pump**

- 8) Evacuate to 50 microns.
- 9) Isolate the vacuum pump and add 50 PSIG (3.4 bar / 340 kilopascal) of helium.
- 10) Vent the helium and repeat steps 8 & 9 at least once. Vent the helium and continue to step 11.
- 11) Final evacuation should be to 25 microns.
- 12) Pressurize the line to the service access with the desired amount of helium pressure.
- 13) Slowly open the service valve to add helium to the system. The final helium charge in the system is specified in Section 5.



**CAUTION**

No more than 5 PSIG (.34 bar / 34 kilopascal) of gas should be added per minute to prevent internal oil contamination to the system. If such contamination occurs, factory service will be required.

- 14) After adding the helium, close the service valve and remove the service Aeroquip® from the service access.

## 8.7 Cleaning

### 8.7.1 Compressor package and cold head

The compressor package and cold head require no cleaning other than wiping the outside of each if it becomes dusty or dirty.



#### **CAUTION**

Never wet either part of the system. *Water getting into the system will void the warranty.*

### 8.7.2 Aeroquip® couplings



#### **WARNING**

Never remove an Aeroquip® coupling from the helium flex lines, cold head or compressor without first relieving the helium charge. The pressure in any of the components can blow off the coupling with sufficient force to cause injury.

If operated in a clean environment, the only parts of the cryorefrigerator system that are likely to require cleaning are the Aeroquip® couplings. The mating surfaces of the Aeroquip® couplings can get particles on them when the helium flex lines are detached from the compressor package and/or the cold head.

If an Aeroquip® coupling needs cleaning:

- Wipe the mating surfaces of the coupling with a dry, lint-free cloth.
- After wiping, blow off the coupling with clean, dry compressed air.
- Solvents should never be used.
- If any grease or oil gets on the Aeroquip® coupling, contact Cryomech.

## 8.8 Manufacturer only parts

The following parts are available only from Cryomech:

#### Helium flex lines

The helium flex lines must be handled with care. If they become damaged and need to be replaced, new ones must be obtained from Cryomech and installed using the directions in the installation section of this manual.

#### Adsorber

The adsorber needs to be replaced after every 20,000 hours of use. See Section 8.4 for instructions on replacing the adsorber.

#### Cold head

The cold head contains no user-serviceable parts and must be serviced by Cryomech authorized technicians. *Attempting to disassemble the cold head will void the warranty.* See Section 8.3.

Main power cord

If the power cord becomes damaged, a replacement should be obtained from Cryomech.

Cold head motor cord

If the cold head motor cord becomes damaged, a replacement must be obtained from Cryomech.

# Appendix A

**Main Assembly Drawing**

**Reliquefier Stand Assembly  
(Optional)**

**Mounting the Reliquefier to  
Optional Stand**

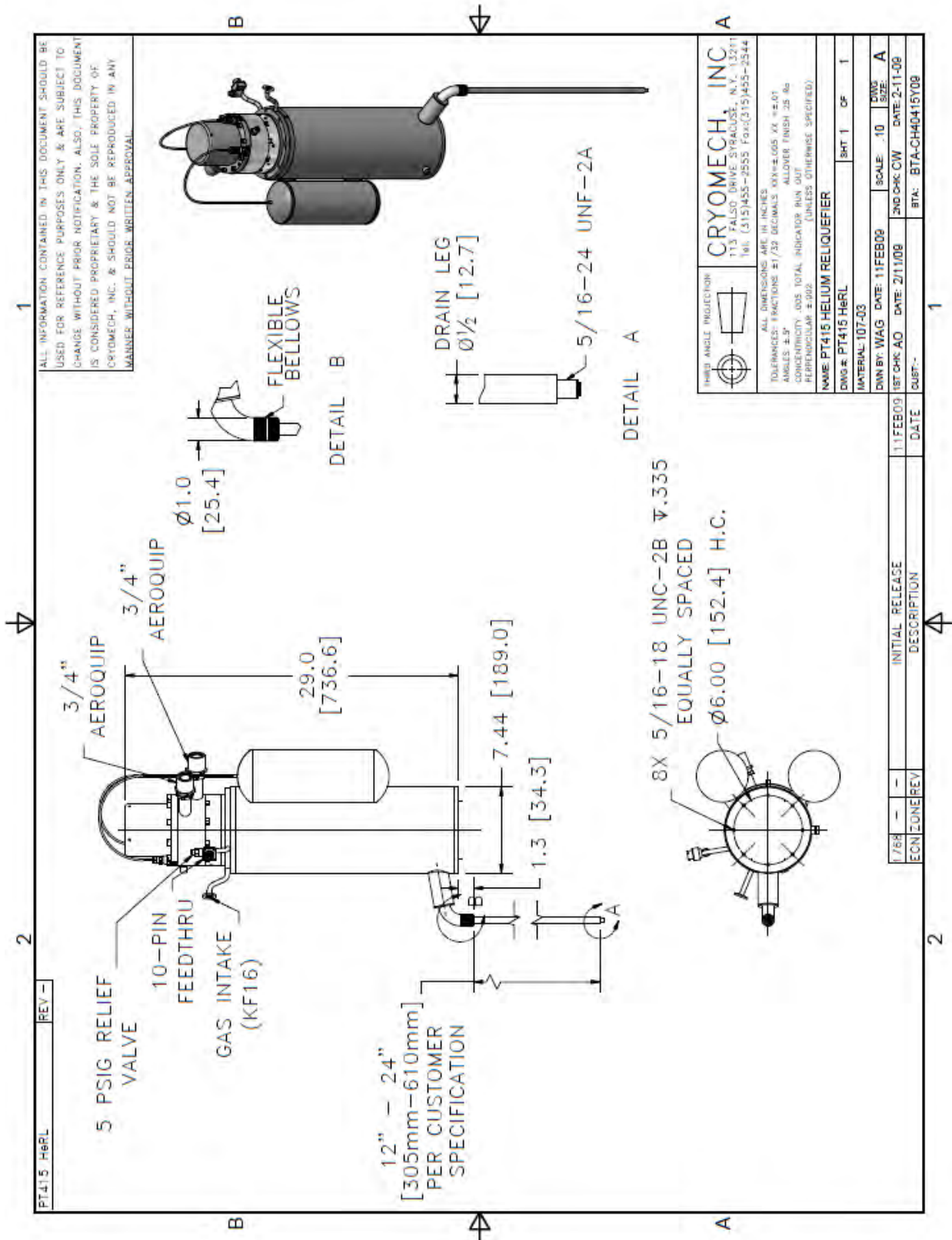


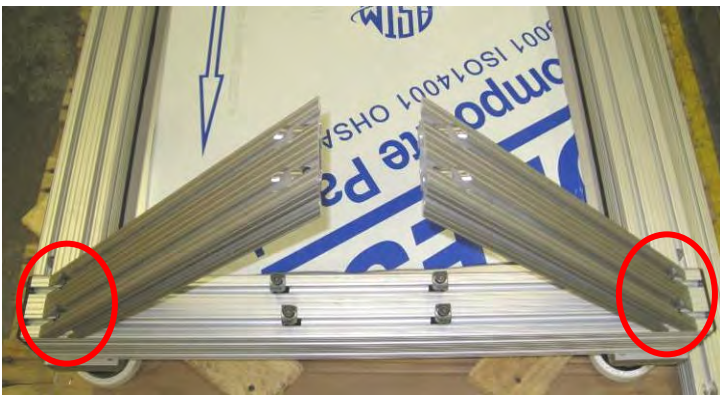
Figure A-1: Reliequifer Main Assembly Drawing

# Reliquefier Stand Assembly

## Tools Required:

- ¼" hex wrench
- (2) ½" wrench's
- 7/16" wrench

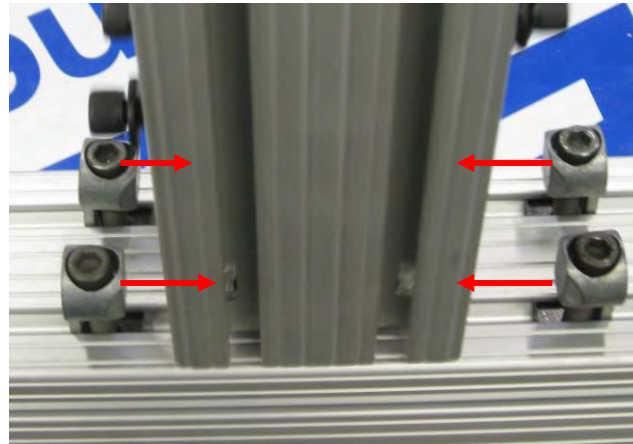
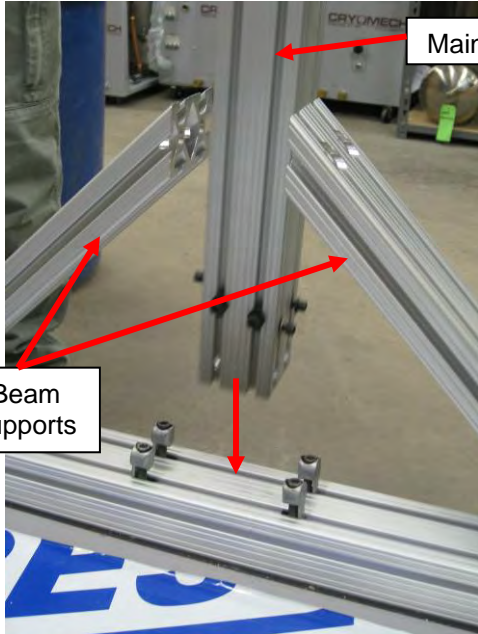
- 1) Carefully unpack the main beam assembly and base assembly.
- 2) Using a ¼" hex wrench, loosen the main beam side supports only enough to be able to move them and slide them towards the corners.



- 3) Place the main beam in between the two side supports and slide the main beam mounting hardware into place. Be sure the winch faces the side of the base assembly with the single rear post mounted to it. Do not fully tighten the hardware down.



**Note: This is step takes two people to complete.**



- 4) Slide the main beam side supports into place resting against the main beam making sure that the main beam is centered onto the base assembly.

- 5) Install all the main beam side support hardware using the method shown for each bolt/washer combination.



A) Remove one bolt from the washer using the 1/4" hex wrench as support for the washer.

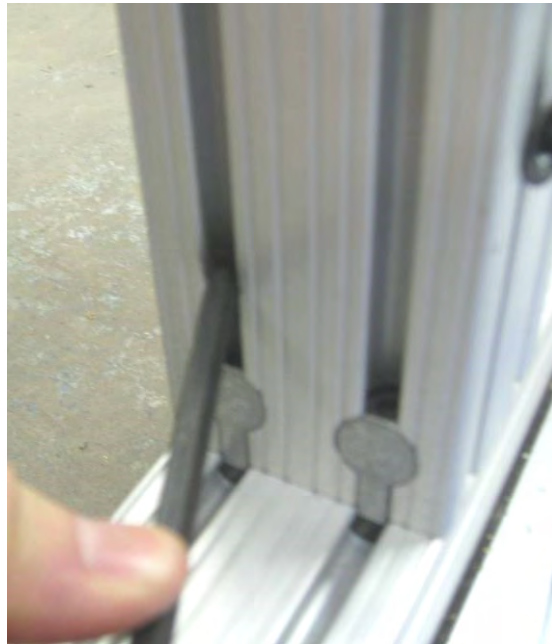


B) Slide the mounting hardware up using the wrench, lining the threads up with the hole and finger tighten the bolt.



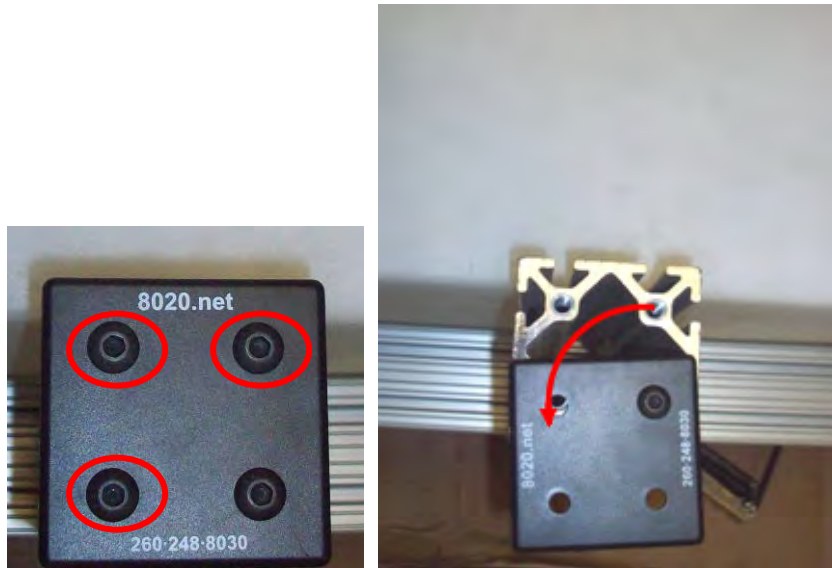
C) Tighten the bolt with the 1/4" hex wrench.

- 6) Tighten the (4) main beam mounting bolts that secure the main beam to the base assembly using the 1/4" hex wrench.





- 7) Remove (3) of the (4) rear post cap bolts and swivel the cap away from the counter weight tank as shown by loosening the fourth bolt.



- 8) Install the rear support beam onto the rear post by sliding it vertically (depicted below) while keeping the mounting hardware loose. Re-install the cap bolts.



**Note: Picture does not show counter weight tank.**

- 9) Using the method of installation in step 5, mount the opposite side of the rear support beam that attaches to the main beam.



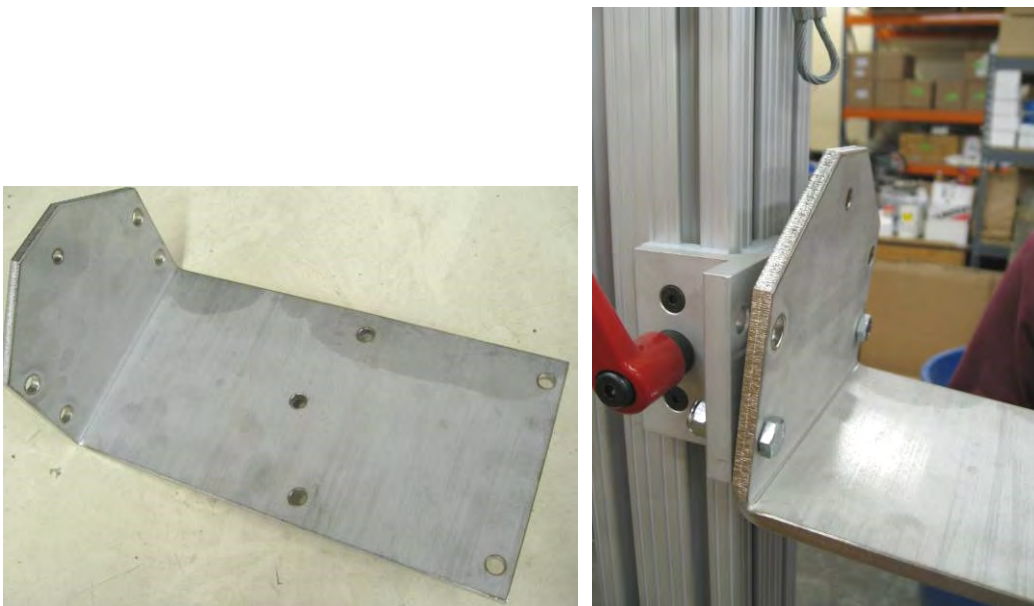
- 10) With the rear support beam able to slide vertically on the main beam and single post on the rear of the base assembly, slide the rear support beam until it is just below the bottom of the winch (this is for ease of hardware installation). Tighten the mounting hardware for the rear support beam into place using the 1/4" hex wrench.



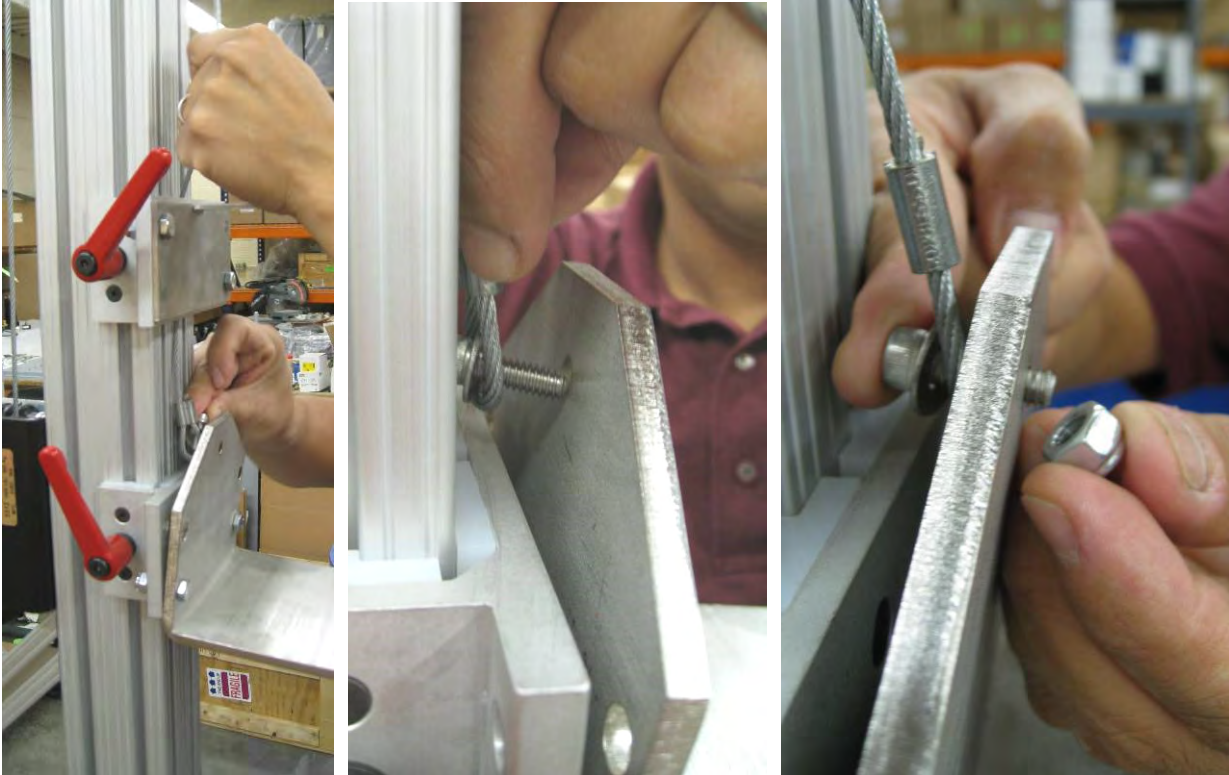
- 11) Install the Reliquefier top support bracket using (4) 5/16"-18 x 1" mounting bolts and nuts as shown in pictures.



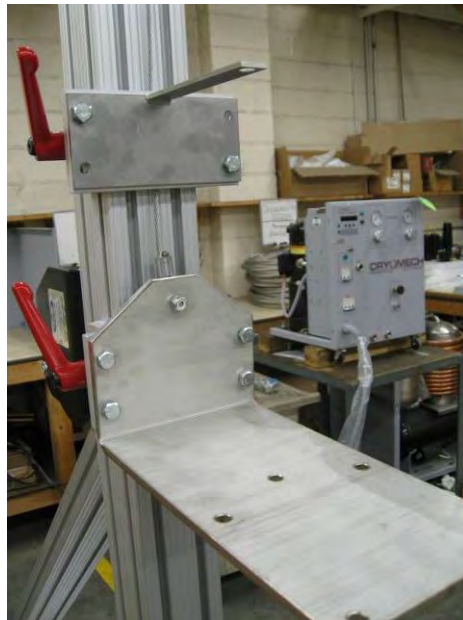
- 12) Install the Reliquefier bottom support bracket using the bottom (2) 5/16"-18 x 1" mounting bolts and nuts. These bolts should be left loose as shown in the pictures.



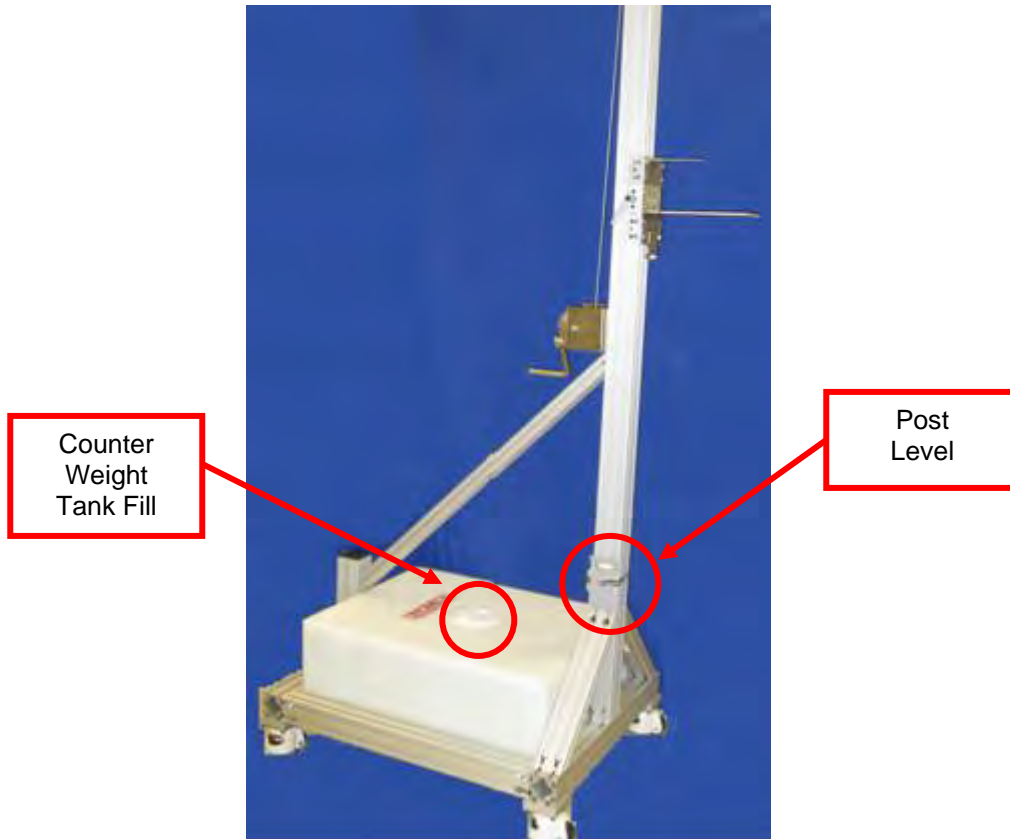
- 13) Crank the winch handle to give slack in the steel cable until the loop in the cable reaches the top hole of the Reliquefier bottom bracket and install the cable retaining bolt as shown.



- 14) Install the other (2) 5/16"-18 x 1" mounting bolts and nuts being sure to tighten all (4) bolts.

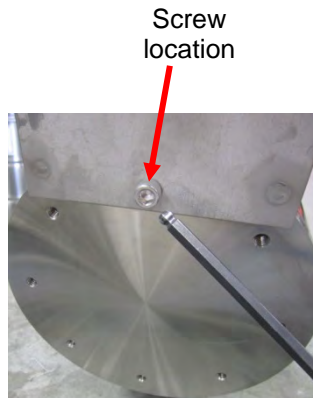


- 15) Fill the counter weight tank with water and using the post level, level the stand before mounting Cryomech Reliquefier.



# Mounting the Reliquefier to Optional Stand

- 1) Carefully place the Reliquefier on a stable flat surface relatively close to the Reliquefier stand.
- 2) Unscrew the protective cap on the drain leg. While supporting the shipping tube, remove the screw that holds the shipping tube to the mounting plate of the Reliquefier assembly. Carefully remove the shipping tube taking care not to damage the drain leg.



- 3) Ensure that there is enough room to stand the Reliquefier without compromising the drain leg. Stand the Reliquefier on the flat surface with the drain leg hanging over the edge of the flat surface.
- 4) Locate the base plate mounting screw that aligns with the reservoir mounting screws. Remove the screw, but keep readily available.



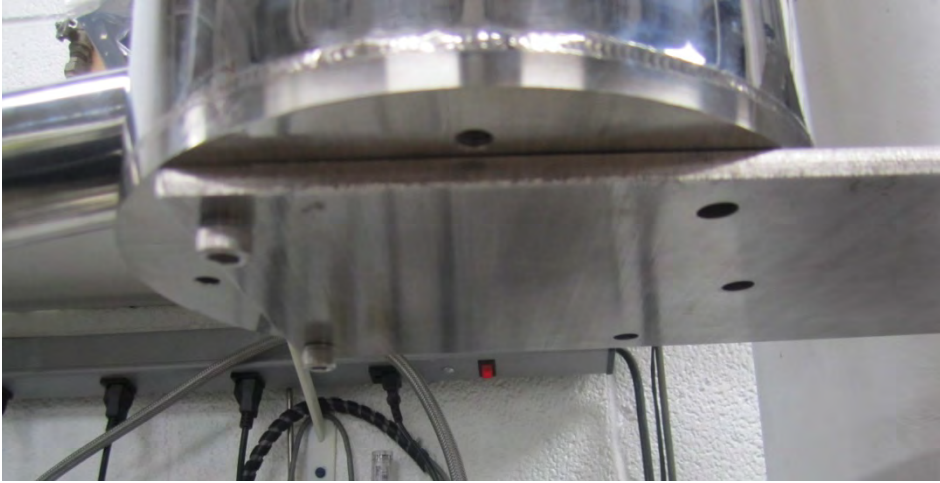
- 5) Adjust the lower bracket on the stand so that the drain leg has enough clearance to avoid damage. Apply the brake on the lower bracket bearing. Adjust the upper bracket so that it is approximately 24" from the bottom bracket.



- 6) Carefully mount the Reliquefier on the lower mounting bracket with the drain leg located opposite the vertical post on the stand.
- 7) While holding the Reliquefier, lower the upper bracket so that the hole on the upper bracket aligns with the hole on the base plate.
- 8) Reinstall the screw that was removed in step 4. For ease of assembly, do not tighten the screw more than a few threads.



- 9) Adjust the Reliquefier mounting plate so that the mounting holes on the mounting plate align with the mounting holes on the lower bracket. Secure the Reliquefier to the bracket using the five (5) 5/16-18 UNC-2B screws supplied.



- 10) Tighten the screw securing the Reliquefier to the upper bracket.
- 11) Complete installation per Section B of the Reliquefier manual.



## Appendix B

# Spray Lubricant Instructions



## Appendix B: Spray lubricant instructions

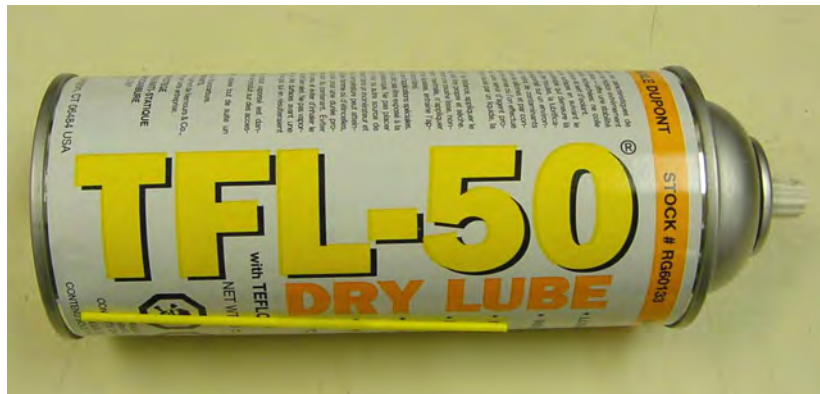
 **CAUTION**

Failure to follow these instructions will cause performance degradation and will void the warranty on your system.

---

**The purpose of this work instruction** is to document the proper use of TFL-50® Dry Lube on Cryomech systems with Aeroquip® connectors.

**Related documents and work instructions:** TFL-50® MSDS



### Connection, Installation

1. Prepare the mating Aeroquips® for connection
  - a. Clean the female and male Aeroquips using a lint free cloth or Q-tip.



**Figure B-1: Cleaning the female Aeroquip**

- b. Make certain the flat gasket is properly seated in the male Aeroquip®.



**Figure B-2: Cleaning the male Aeroquip®**

2. Thread the female Aeroquip® onto the male by hand, until tight.



**Figure B-3: Female to male connection, hand tightened**



### **CAUTION**

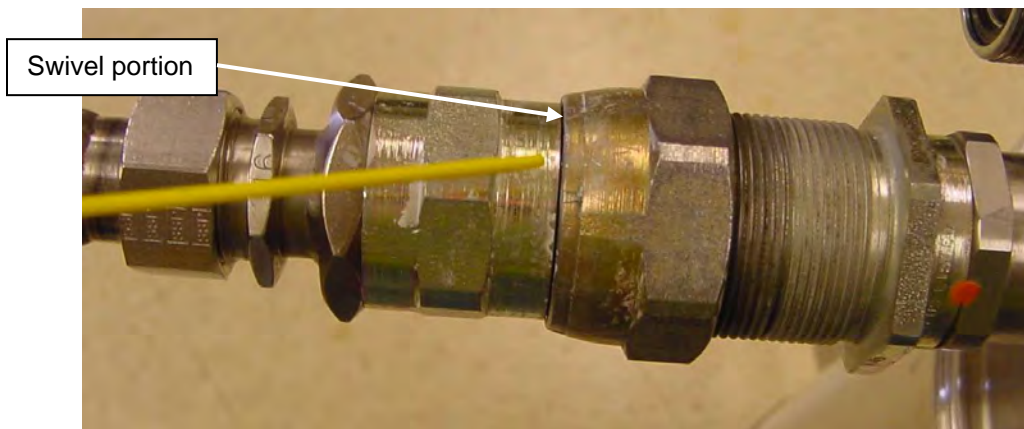
Never apply lubricant to the open ends of the Aeroquips®. Doing so will contaminate the system and void the warranty. Apply lubricant to the Aeroquips® only after they are hand tightened together.

3. Before using this product carefully read and follow the instructions on the can. Only a small amount of TFL-50® should be used. A typical amount is shown in Figure B-4. The spray nozzle should only be depressed for 1 second or less. If a white film appears on the surface, too much lubricant has been applied.



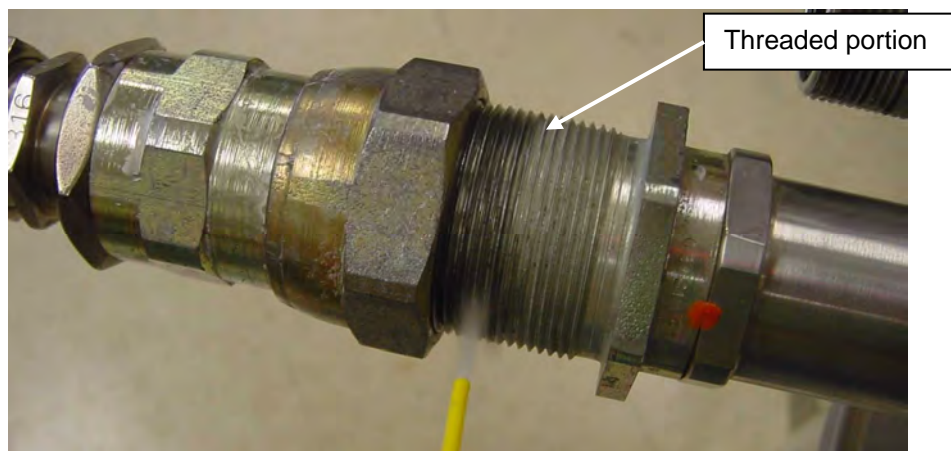
**Figure B-4: Typical amount of lubricant**

4. Apply a small amount of TFL-50® to the swivel portion of the female Aeroquip®.



**Figure B-5: Apply lubricant to swivel portion**

5. Apply a small amount of TFL-50® to the threaded portion of the male Aeroquip®.



**Figure B-6: Apply lubricant to threaded portion**

6. Use wrenches to tighten the Aeroquips® completely (see manual for instructions).

**Disassembly**

1. Apply a small amount of TFL-50® to the swivel portion of the female Aeroquip® as shown in Figure B-5.
2. Use wrenches to loosen and remove the Aeroquips® (see manual for instructions).